

## **CUSTODIAL**

This section of the Washington University School of Medicine (WUSM) Design Standards addresses the following requirements for Custodial and its application in WUSM projects:

### **CUSTODIAL SPACE REQUIREMENTS TRASH, RECYCLING, BIOHAZARD, AND HAZARDOUS WASTE TOILET ROOM ACCESSORIES**

A Custodial Meeting shall be conducted to review all Custodial related spaces and functions, exceptions to materials and finishes, trash and recycling needs, and toilet accessories during the Schematic Design Phase. Preview options with WUSM Senior Planner / Project Manager prior to this meeting.

References:

Standards References:

[EH&S – BIOHAZARD AND HAZARDOUS WASTE](#)

[FINISHES](#)

[SPECIALTIES – TOILET PARTITIONS](#)

[SPECIALTIES – TOILET ROOM ACCESSORIES](#)

## CUSTODIAL SPACE REQUIREMENTS

### DESIGN GUIDELINES

1. A minimum of one (1) Custodial Closet per 25,000 square feet shall be provided. While Custodial Closets are necessary for each floor of a building, consideration will be given to sharing Custodial Closets within clusters of buildings. Verify needs and location of Custodial Closets with the WUSM Project Manager and the Custodial Director.
2. New buildings greater than 100,000 square feet shall also provide space for a Large Custodial Equipment Storage Room and a Housekeeping Supply Holding Room. Additionally, a Supervisor's Office, Meeting Room, Custodial Staff Break Room, and Staff Locker Room shall be provided. Verify specific needs with WUSM Project Manager and Custodial Director during the Schematic Design Phase.
3. Custodial needs for new buildings with fewer than 100,000 square feet, and for renovations within existing buildings, shall be reviewed with WUSM Project Manager and Custodial Director to identify the necessary functions.

### PRODUCT REQUIREMENTS

1. Custodial Closets must contain the following:
  - a. Room finishes: Fiberglass Reinforced Panels (FRP) on walls up to 4-feet, VCT or sealed concrete floor, vinyl base, and lay-in ceiling with utility lighting.
  - b. Janitor's floor sink with 16" high curb.
  - c. Faucet with T-connection and backflow preventer.
  - d. Chemical dispenser mounted over janitor's sink. Dispensers are supplied by the chemical supplier.
  - e. Stainless steel shelving to accommodate one week's supplies, mop holders. Verify needs with WUSM Project Manager and the Custodial Director.
  - f. Quad GFI outlet.
  - g. Floor area for one recycle bin, one trash bin, and one mop bucket. Verify needs with Project Manager and the Custodial Director.
  - h. 3'-6" wide door.

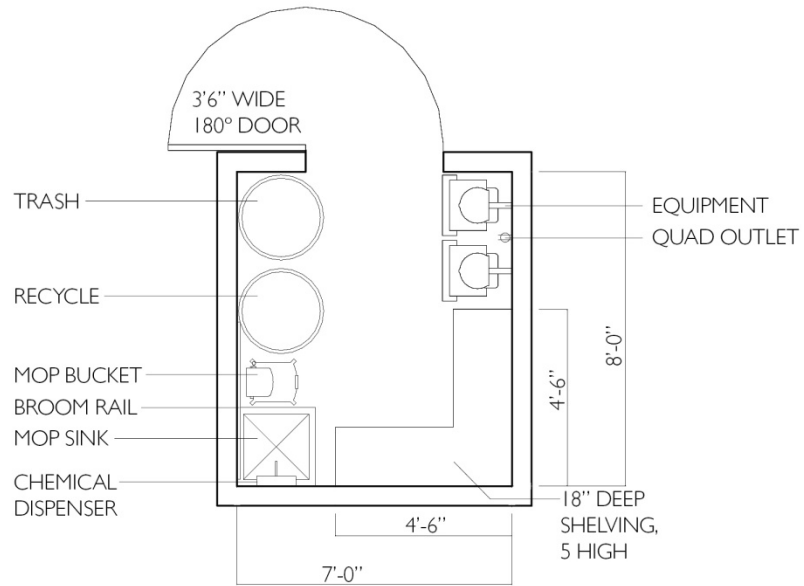

CUSTODIAL CLOSET TYPICAL LAYOUT

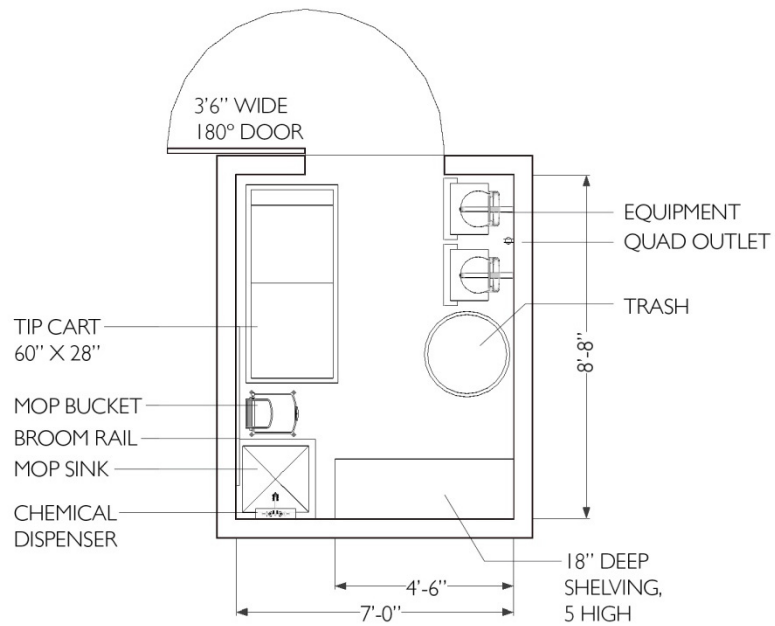

CUSTODIAL CLOSET LAYOUT W/ TIP CART

2. In addition to the typical Custodial Closet on each floor, provide the following spaces per building with more than 100,000 square feet.
  - a. Large Custodial Equipment Storage Room and Housekeeping Supply Holding: Verify specific needs with Project Manager and the Custodial Director. Custodial Equipment Rooms can contain automatic scrubbers, buffers and polishers, tip carts, manual cleaning equipment and products, etc.
  - b. Supervisor's Office, Custodial Staff Break Room, Locker Room, and Meeting Space shall be sized to meet the needs of the Custodial Staff. For renovations and buildings with fewer than 100,000 square feet, custodial meeting space may be shared within the break room or other available conference space. Verify specific needs with Project Manager and the Custodial Director.

**TRASH, RECYCLING, BIOHAZARD, AND HAZARDOUS WASTE**

**DESIGN GUIDELINES**

1. Trash & Recycling Containers: Provide space to accommodate trash and recycling containers within the following functional areas:

PLANNING FOR TRASH & RECYCLING CONTAINERS	TRASH				RECYCLING			Notes
	30-35 Gallon	21 Gallon 1/2 Round Gray	23 Gallon Open Top Rectangular Gray	7 Gallon Open Top Black	30-35 Gallon	23 Gallon Open Top Rectangular Blue	7 Gallon Open Top Blue	
Building Lobbies	●				●			4
Elevator Lobbies								2
Restrooms - Multi-stall		●						1
Restrooms Single		●						1
Work/Copy Rooms			●			●		
Kitchenettes & Coffee Areas			●			●		
Private Offices							●	2
Open Office Workstations							●	2
Conference Rooms			●			●		
Classrooms			●			●		
Waiting Areas				●				
Auditoriums	●				●			4
Laboratories			●			●		1, 3
Other Research Areas			○			○		1, 3

● Permitted

○ Permitted as appropriate to project

- 1 Coordinate Bio-Hazard , Sharps, and other waste with WUSM PM, [EH&S](#), and User Groups.
- 2 Trash receptacles are not typically provided in this location.
- 3 Verify need with WUSM PM.
- 4 Customized, WUSM PM choice.

2. Built-in, recessed trash receptacles in restrooms are by exception only.

## **TOILET ROOM ACCESSORIES**

### DESIGN GUIDELINES

1. Soap Dispensers, Toilet Tissue Dispensers, Paper Towel Dispensers, and Trash and Waste Containers are furnished by the Owner and installed by the General Contractor. Refer to [SPECIALTIES - TOILET ROOM ACCESSORIES](#) for additional information.