

**Washington University School of Medicine,
BJC and Telecommunications Facility Corporation
Low Voltage Voice and Data
Pathways and Spaces Standard
January 21, 2016**

Document Purpose:

The purpose of this document is to provide a planning guide for the design of low voltage pathways and space for all new facilities and major renovations. This document is based on information gleaned from best practice documentation, EIA-568C, EIA-568B, TSB-469. It provides ongoing Voice & Data guidelines and confirms established "STANDARDS" that apply to any construction or maintenance of BEFs (*Building Entrance Facility*), Main TRs (*Main Telecommunication Room*), TRs (Telecommunication Room) or any other communications facilities that are the responsibility of the Telecommunications Facility Corporation (TFC), BJC Network Operations and Washington University School of Medicine (WUSM) groups as occupants. Only contractors with a current BICSI RCDD on staff and listed on the approved WUSM/BJC/TFC Communications Group's Approved Low Voltage contractor list will be allowed to bid low voltage structured wiring projects. These standards will be employed when constructing new, or modifying existing communications rooms. The standards are based on a basic rectangular shaped room of adequate dimensions. Since each instance of provided space can be unique in nature, these standards shall be adapted to the space provided when approved by the appropriate Communications group (s). Access to the BEF & TR's will be unobstructed. Access will be from a hallway whenever possible. Avoid using an adjoining office or user space for access. A badge swipe for the door is the required method of access to the BEF and TR's for BJC but is the preferred method of access for WUSM. Anytime drilling is taking place in a BEF/MTR, TR or any communications facility the use of a HEPA filter is required. This document is also intended to provide standard practices for ANY installation(s) or maintenance of equipment, furnishings or wiring housed within each of these locations. Additionally, it provides installation guidelines and procedures for BJC/WUSM/TFC low voltage cabling specific to Data and Voice communications within BJC/WUSM facilities. This document is to be provided to all low voltage contractors by the specific group bidding the project. The processes and standards contained herein shall supersede any other previously dated Communications Standards documents provided for 'Low Voltage' work unless an exception is specifically agreed upon by TFC, BJC Network Operations, and WUSM Network Operations.

BJH, MBMC & SLCH Locations require proper permitting prior to installation. The Standards information contained within this document should be used in conjunction with and applied to, each project specification. Each bid request will uniquely define the scope for a particular project and the information contained herein SHOULD NOT be interpreted as an opportunity to substitute requirements or scope specific to any project. Any bidder who has not been given specific requirements & scope for a given project should contact the project manager for the project's requirements.

Document Scope:

The scope of this document includes physical rooms and spaces, pathways, racks, conduit systems, cable trays, raceways, and any other physical system used to support or terminate low voltage cabling systems. This document provides an overall specification of cable types, services, and termination equipment. This document should be used solely for the purposes of planning and designing the appropriate telecommunication rooms, building entrance facilities, cable tray and raceways systems, and all conduits used for low voltage voice and data.

Document Outline:

Part 1: Planning and Design p. 5

Part 2: Building Entrance Facilities and Conduit Feeds p. 5

Part 3: Building Layout and Conduit Design p. 7

Part 3a: Building Layout p. 8

Part 3b: Vertical Backbone p. 9

Part 4: Telecommunications Rooms – Size and Rack Layout p. 11

Part 4a: Main Telecommunication Rooms – Main TR p. 11

Part 4b: Telecommunication Rooms – TR p. 13

Part 4c: Oversized Telecommunication Rooms p. 16

Part 5: Cable Tray and Horizontal Pathways p. 17

Part 6: Grounding and Bonding p. 19

Article 1 – Building Single Grounding Point p. 20

Article 2 – Telecommunication Main Grounding Buss Bar (TMGB) p. 21

Article 3 – Telecommunications Bonding Backbone (TBB) p. 21

Article 4 – Telecommunication Grounding Buss Bar (TGB) p. 22

Article 5 – Grounding and Bonding Building Entrance of Facilities (BEF), Main Telecommunication
Rooms (MTR) and Telecommunication Rooms (TR) p. 23

Article 6 – Appropriately sizing ground conductors p. 24

Article 7 – Best Practices p. 24

Part 7: General Information p. 28

Part 7a: Data Equipment Racks p. 28

Part 7b: Voice Equipment Racks p. 28

Part 7c: Room Layout p. 28

Part 7d: Data Wire p. 30

Part 7e: Data Cabling p. 30

Part 7f: Voice Cabling p. 31

Part 7g: Fiber Optic Cabling p. 32

Part 7 h: Labeling: Voice/Data – Fiber Trunks p. 34

Part 7i: Raceways and Cable Runs p. 36

Part 7j: Additional Information p. 37

Part 7k: Architectural Drawing Standards p. 37

Part 8: Wireless p. 40

Part 9: MOB p. 41

Part 10: POB p. 42

Part 11: COB p. 43

Part 12: Outside Plant p. 44

Part 13: Barrier and above ceiling Policies and procedures p. 45

Part 13a: BJH Barrier Integrity Policy and Procedures (BIPP) p. 45

Part 13b: BJH Barrier Access Permit Policy and Procedures (BAP) p. 52

Part 13c: SLCH Access and Above Ceiling work Policy p.58

Part 13d: MBMC Facilities Standard Practices. P. 61

Appendices:

Appendix A – Grounding and Bonding Terms and Abbreviations p.25

Appendix B – Telecommunication Terms and Abbreviation p.25

Appendix C – Building Grounding and Bonding Diagram p.26

Appendix D – Telecommunication /Equipment Room Grounding and Bonding Diagram p.27

Appendix E – Wall Plate Labeling Diagram p.66

Appendix F – CAT5e Conduit Fill Ratio Planning Guide p.67

Appendix G – CAT6 Conduit Fill Ration Planning Guide p.67

Appendix H – CAT 6 Cable Tray Fill Capacity p.67

Appendix I – WUSM/BJC/Main TR/ TR Power Requirements p. 69

Appendix J – Elevator Voice Cable Design p.70

Appendix K – Paging for Academic Sites p.71

Appendix L – Contractors Standards / Code of Conduct p 74

Appendix M – Copper Field Testing Requirements p 76

Appendix N – Fiber Field Testing Requirements p 85

Appendix O – Manufacturer Part Numbers p 94

Appendix P – Changes to the Document p 98

Part 1: Planning and Design

The goal of the planning and design for low voltage pathways and spaces is to ensure the current user's needs are met, the low voltage contractors have the pathway and spaces required to easily and safely install the cabling systems, to ensure the low voltage systems perform to WUSM/TFC/BJC's highest standards, and to ensure adequate growth space for new services, new workspaces, and technological change.

A documentable methodology is the easiest way to ensure both Design & Construction and BJC/TFC/WUSM cover all the bases and plan ahead for all new facilities and major renovations.

Part 2: Building Entrances Facilities and Conduit Feeds

All Major⁰ WUSM/BJC/TFC Medical Center campus facilities are designed with a primary (A) and secondary (B) conduit feed. The primary conduit feed for all major facilities (I.E. CSRB, PRB, FLTC) are run to the nearest or most cost effective TFC conduit corridor system manhole of the. The secondary feed will run either to a secondary TFC corridor system manhole using a diverse route or to an adjacent or nearby facility using a diverse indoor or outdoor route¹. Non-major buildings (I.E. 22 North Euclid, Storz, Biohazard) are designed with only a primary (A) conduit feed or may even utilize a leased circuit if it is not located on campus. Primary conduit feeds for non-major facilities may be run to the TFC corridor system, WUSM fiber, or a service provider's infrastructure.

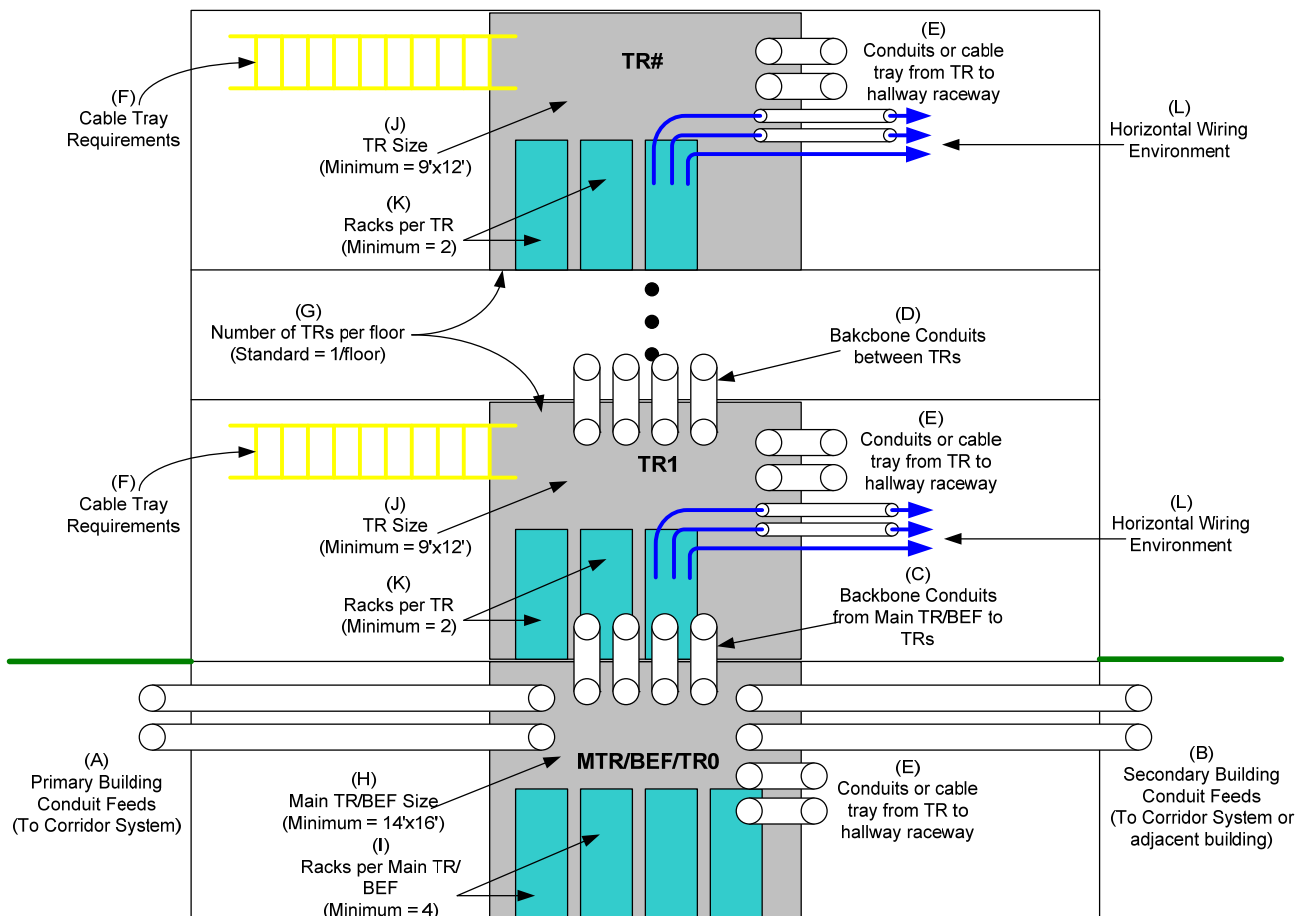

Exhibit 1a: Building Low Voltage - Pathways and Space

⁰ Major is identified as “clinical Treatment facilities or Critical Equipment Areas.”

¹ In most situations WUSM/BJ will utilize TFC resources for outdoor routes unless not approved by the TFC Board.

Refer to (A) and (B) in Exhibit 1a: for more details. The following decisions need to be made when planning the Building Entrance Facility (BEF)(H) and/or Main Telecommunications Room (Main TR) (H):

- Number of 4” conduits required for the Primary Building Conduit Feed (A)
- Number of 4” conduits required for the Secondary Building Conduit Feed (B)
- The location of the BEF and Main TR in relation to the location of the entry point of the primary and secondary conduits.

The normal standard for the number of primary building conduits is 4 – 4” conduits. This provides 2 – 4” conduits to the corridor system for fiber optics and 2 – 4” conduits for diverse routing. Some factors to consider are:

- Number of fiber trunks required upfront
- Number of potential future feeds

For buildings considered non-major, 2 – 4” conduits are typically sufficient².

Refer to the location of the Main TR (H) and BEF/Main TR (H) in Exhibit 1b: below. If the Main TR (H) and BEF (H) are two separate spaces, the primary (A) and secondary (B) building conduit feeds must be run from the BEF (H) to the Main TR (H). If the BEF (H) and Main TR (H) utilize the same space, this extra length of conduit is not required but any outdoor rated cable must be terminated within 50’ of entering the facility.

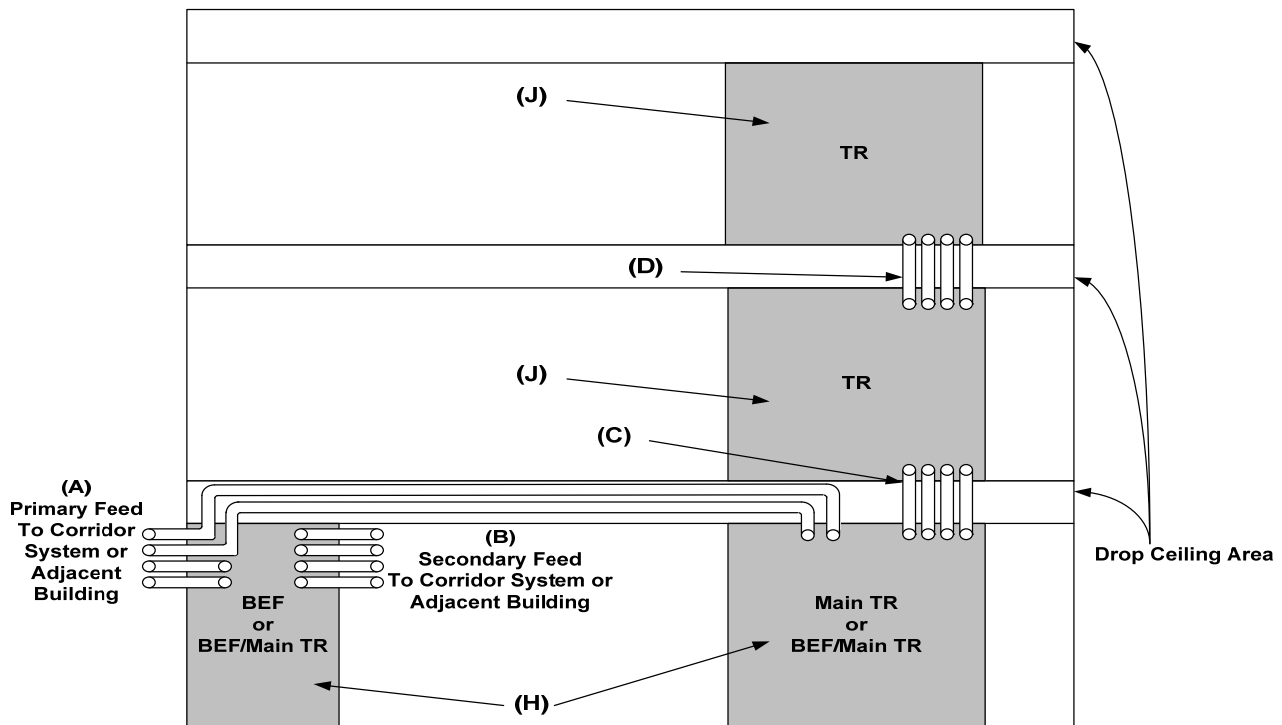

**Exhibit 1b: Building Low Voltage -
Pathways and Space
Main TR and BEF Locations and Spacing**

The location of the BEF often dictates the conduit cost for a new facility. It may appear to be more cost effective to locate the BEF on an exterior wall to make the entry point simpler and reduce the amount of internal conduits. However, in most cases, if the BEF is located on the exterior of the facility, conduits may still need to be run to the Main TR or if the BEF and Main TR coexist, the vertical backbone (C) to the Telecommunication Rooms (TR) (J) may be longer and most costly if the Main TR and TRs do not stack or line up vertically.

² In most cases, an as needed decision is made for non-major facilities. However, the cost of adding future outdoor conduits should always be considered.

Always keep in mind space for planned equipment, access to the equipment, and future equipment growth when designing rooms.

Factors that must be considered when designing the room include but are not limited to the following:

- Required equipment space.
- Providing for future expansion.
- Centralized UPS System Space
- Large equipment and cabling access.
- Access Provider (e.g., a telephone company).
- Proximity to mechanical equipment and electrical service.
- Electromagnetic Interference (EMI) sources.
- Proximity to and access for telecommunications cable pathways.
- OSHA Safety considerations.
- Fire protection. Consider using a “dry pipe” sprinkler system.
- Flood prevention.
- Floor loading.
- Grounding.
- Lightning. Provide for 500 lux (50 foot-candles) measured 1m (3ft) AFF, with at least one emergency light.
- Ceiling Height. Eight foot is acceptable, ten foot is optimum.
- Ensure that HVAC will:
 1. Allow for continuous and dedicated environmental control 24x7, 365 days a year. Place on emergency power if available.
 2. Maintain temperature range of 18° C to 24° C (64° F to 75° F), relative humidity range 30% to 55%.
 3. Provide for positive pressure with a minimum of one air change per hour.
 4. Ensure dissipation of active device (s) generated heat.
 5. Create a positive pressure in the TR. (5 to 10 CFM above the exterior hallway)

Unacceptable locations include space in or next to, but are not limited to:

- Washrooms
- Custodial closets
- Mechanical rooms
- Storage rooms
- Loading docks
- Space that contains:
 1. Hydraulic equipment and any other vibrating heavy machinery.
 2. Plumbing
 3. Cleanouts
 4. Steam pipes

Part 3: Building Layout and Conduit Design

The number of TRs per building is a critical decision in the planning and design process. There are several factors to consider when determining this number:

- Size of the floors – the 295’ maximum length for CAT6 and CAT6A UTP needs to be preserved at all cost
- How each floor will be used? Is it lab or office space? The way in which the floor is utilized typically dictates the number of UTP lines required by the tenant.
- How many workstations or work spaces are located on each floor?
- How many lines will be run to each workspace? The standard for WUSM is 1 CAT6 for new buildings. The standard for BJC is 1 CAT6. In VoIP installations the standard for WUSM is 1 CAT6. The standard for BJC is 1 CAT6 for each data device. A voice device can share a data device connection. Consult with appropriate data analyst or project manager for specifications.
- Will all lines be run to the same floor or are there areas such as modular furniture or flush mount floor outlets that require the lines to run to the floor below?
- Are there any high concentration areas such as a seminar room, auditorium, or classroom?

Part 3a: Building Layout and Design

Exhibit 2a: below details the location issues of each TR (J). Note that the actual path of each UTP is much longer than the closest point between the workspace and the TR (J). For planning purposes, use a 225' radius from the center of each TR to provide a rough estimate of the coverage area. By using a 225' radius, we allow some additional cable length for the rises and drops from the ceiling to the workspace and TR rack system and the potential turns in the building pathways. This is a guide and may not be applicable in all situations. In some facilities, more than one TR per floor may be required.

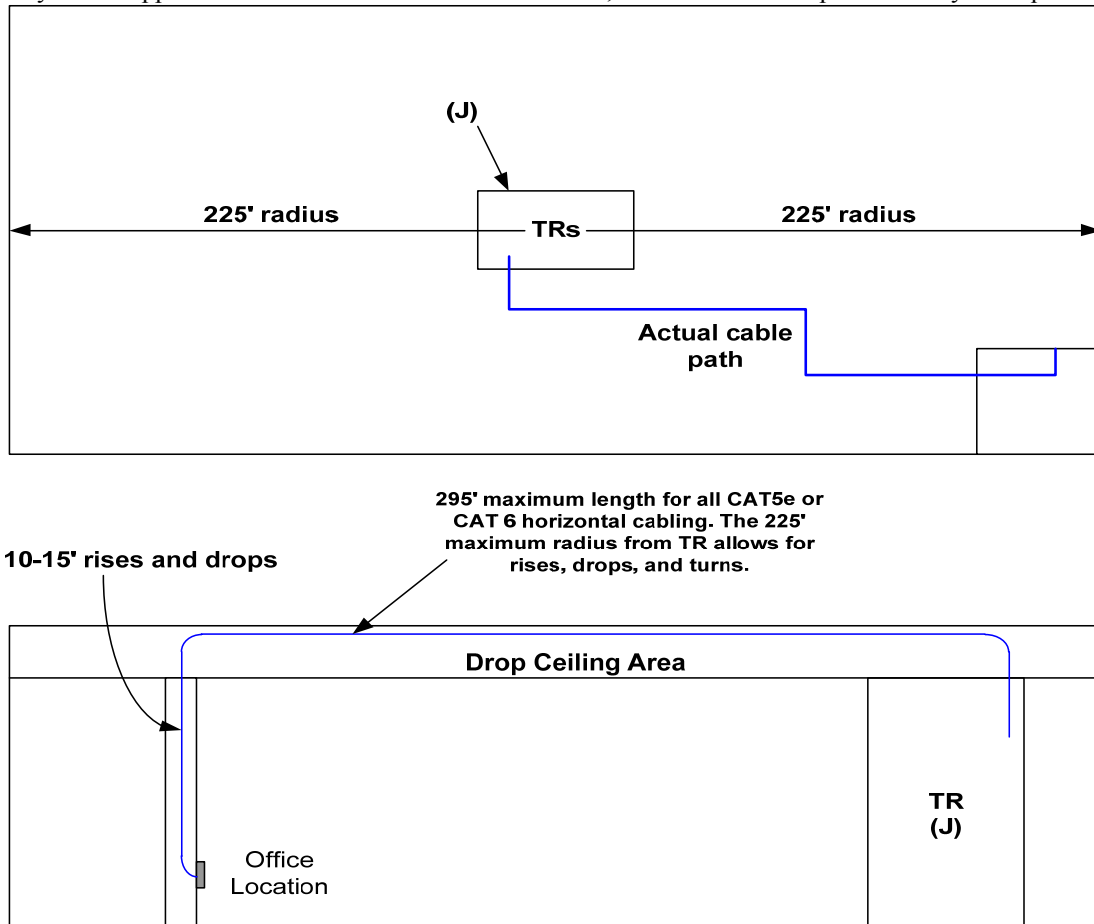

Exhibit 2a: Building Low Voltage - Pathways and Space TR Locations and Spacing

Keep in mind that the shape of the building may also have an impact on the number of TRs required. Buildings with a single, main hallway tend to be more efficient in terms of cable length. However, uniquely shaped buildings such as CSRB make the use of a single TR per floor difficult.

One TR to serve each floor is preferred as long as the following conditions are met:

- The size of the TR is large enough to support capacity requirements
- The number of vertical backbone conduits is enough to support the number of cables plus growth that will run to the floor
- TRs are stacked as much as possible to make the running of cables between floors simpler and less expensive
- Lines terminating on a particular floor at the workspace should terminate in the respective TR. For instance, if the TR on the 5th floor is designed to feed the 5th floor, a cable on 4 or 6 should not terminate in that closet even if it needs to pass through the floor.

The number of TRs is also dependent on the number of cables per floor. This document will provide more detail on the TR size and layout in Part 3:

Part 3b: Vertical Backbone Risers

The layout of the BEF and Main TR in respect to the TRs (J) has a big impact on the way a building is fed vertically. Vertical feeds include:

- Fiber Optic Feeds for data network
- Fiber Optic Feeds for voice network (if separate)
- Copper Feeds for standard voice services
- Grounding Bus
- Fiber/copper feeds to support Facilities/Building Automation and Security system requirements.

Refer to the layout of the TRs (J) in Exhibit 2b: below. The most efficient means for locating TRs is to stack them vertically. This allows for conduit or core drills between floors rather than 4" conduit extensions that are required to rise and run through a portion of a floor before entering the next TR. Vertical stacking of TRs also reduces the cost of vertical fiber and copper feeds.

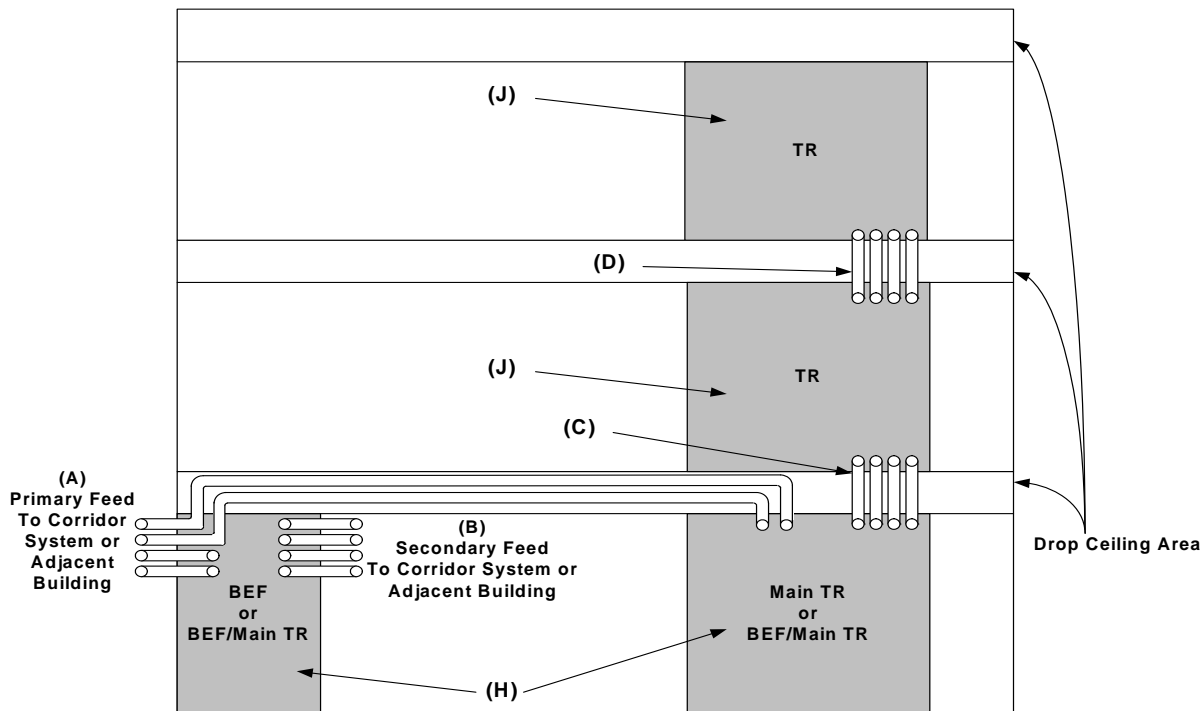

Exhibit 2b: Building Low Voltage -
Pathways and Space
Main TR and BEF Locations and Spacing

The following decisions need to be made when planning and designing vertical feeds:

- The number of EZ Path conduits and/or EZ Path Modular Floor Grid System between the Main TR and the first TR
- The number of EZ Path conduits and/or EZ Path Modular Floor Grid System between successive TRs
- The addition of a EZ Path 22 conduit for grounding and bonding system

The standard number of vertical backbone risers (C) between the Main TR (H) and the 1st TR (J) is 4 – Series 44 EZ Path conduits and 1 – Series 22 EZ Path conduit. This provides 2 – Series 44 conduits for fiber optic trunks, 2 – Series 44 conduits for twisted pair trunks and coax feeds, and 1 – Series 22 EZ Path conduit for the building ground buss. These numbers may need to be increased based on several criteria:

- How many floors need to be fed? At times, more conduits are required between the lower floors to support homerun feeds to the upper floors. The following guidelines can be used to plan vertical conduits for fiber optics:

- Standard 12 SM / 24 MM armored fiber optic cable – 11 armored trunks per Series 44 conduit
- Standard 24 SM / 48 MM armored fiber optic cable – 8 armored trunks per EZ Path Series 44 conduit
- Standard 48 SM / 48 MM armored fiber optic cable
- 1.25” Fiber Innerduct³ - 4per EZ Path Series 44 conduit
- Size of the copper trunks required for each TR above. Obviously, the larger the copper trunk, the more space within a 4” conduit will be utilized.
- Future growth or additional floors to be built out needs to be considered during the planning phase.
- How many horizontal UTP cables will need to run between floors? In most cases, when a TR per floor is planned, running UTP between floors is not an issue. However, there are some cases where modular furniture or flush mount floor outlets are stubbed down into the plenum space below. These cables may need to be run through the floor below and then run up through the risers to the appropriate TR. The following fill ratios apply to EZ Path Series 44 conduit (For more details refer to the CAT5e and CAT6 fill ration guides in Appendices F and G.) or otherwise specified by local requirements:
 - CAT5e – 244 UTP in a EZ Path Series 44 conduit
 - CAT6 – 180UTP in a EZ Path Series 44 conduit

In facilities where more than one TR is required per floor, a vertical backbone for each “stack” of TRs is recommended. The Main TR can feed multiple sets of vertical backbone risers to gain some efficiency. However, at least one set of verticals backbone risers will be required run horizontally from the Main TR before it begins its vertical path to the TRs. See Exhibit 2c below for more details. Note: Conduit between Main TR/BEF to first TR not always required.

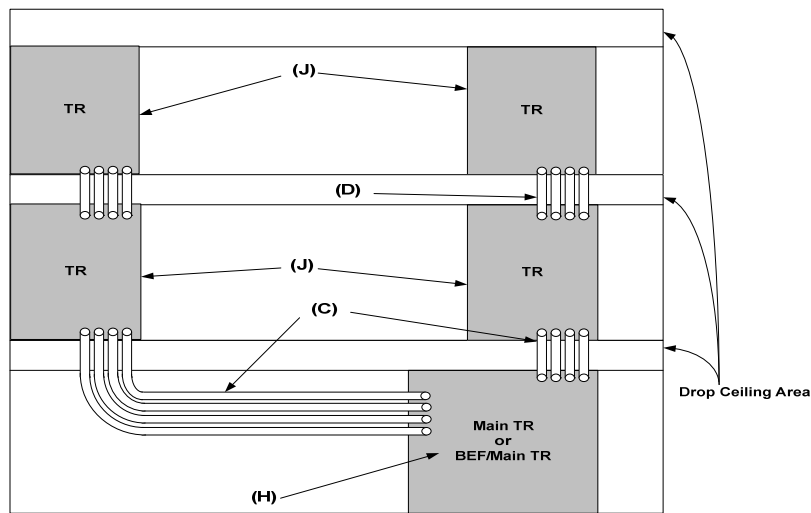

Exhibit 2c: Building Low Voltage - Pathways and Space Multiple Risers

³ Innerduct is a plenum or non-plenum rated plastic tubing used to protect fiber optic cable when running through pathways and spaces. Armored fiber trunks are easier to run and more cost effective.

Part 4: Telecommunications Rooms – Size and Rack Layout

There are several factors that may impact the size and layout of the Main TR or any TR. Some factors include the number of floors, the way in which the facility will be used, traditional voice versus VoIP, is it a CAT6 installation, and numerous other factors.

Part 4a: Main Telecommunication Room – Main TR

The following questions should be answered during the planning and design phase in regards to the size and rack layout for the Main TR:

- Is the Main TR standalone or is it also serving as the BEF?
- Is the Main TR also used as a TR for one or more floors?
- Is the Main TR used as an aggregation point to feed fiber or services to other facilities?
- Is there any requirement to house additional supporting equipment such as standalone Centralized UPS, Cooling, Voice EPN, or Building Automation equipment?
- Is this facility going to support a single campus network (CareNet, WUCON, WUSTL, WUMRACN, and DMZ) or will support two or more networks?

In most cases, when planning a new facility, the Main TR is going to serve that facility only. However, in some cases, as we plan for future technology and growth, we often need to plan for a Main TR to act as a cross-connect point for other facilities. If this is the case, more racks are required to support multiple Cisco switches and Fiber Optic enclosures.

A standard Main TR, which typically acts as a TR for the lower level, is depicted in Exhibit 3a: below. A Main TR is equipped with the following:

- 1 CPI Rack (K) for Fiber Optic terminations
- 1 CPI Rack (K) for the Building Aggregation Switch and UPS systems
- 2 CPI Racks (K) for the TR equipment and UTP terminations
- All CPI Racks are attached to two vertical managers with extended fingers. (M)⁴ Size to be determined during design.
- 4 – 4” conduits (minimum) to the primary feed (A)
- 2 – 4” conduits (minimum) to the secondary feed (B)
- 4 – 4” conduit stubs (C) or “cores” (minimum) to the first TR (J)
- 1 – 2” conduit stubs or “core” for the grounding bus
- 1 – Voice 66 Block frame for backbone terminations. Size to be determined during design.

A standard Main TR should be planned and designed to include the following criteria:

- The minimum room size is 14’ x 16’. This will allow the installation of 4 CPI racks (K) as detailed in Exhibit 3a: below.
- The racks (K) are 3’ in depth including the actual rack depth plus the equipment depth. This should leave 5’ of additional space. The racks should be located to allow:
 - 5’ of clearance on the front, or service side, of the racks
 - 3’ of clearance on the back, or termination side, of the racks
- The equipment widths are:
 - Racks – 21.25” W
 - Vertical Managers – 6” W with extended fingers or 10” W with extended fingers
 - The total equipment length is 136” (11’ 4”) using 6” vertical manager
 - This leaves a 4’ clearance to service the back of the racks and allow entry into the Main TR⁵
- 3’ additional feet of either front or rear clearance are required to support TFC EPN, UPS, cross-connect frames as detailed in Exhibit 3a.

NOTE: In all data racks, signal cabling will be installed on the front of the rack, and power and grounding will be stalled on the back side of the racks. The appropriate owner (WUSM, BJC, or TFC) will determine which side will be the front side of the rack for each installation.

⁵ Vertical Managers between racks are shared. To determine the number of vertical managers, use the number of racks plus one. (R + 1)

⁶ The minimum clearance for safe passage around, or behind, racks and equipment is 3’. This also allows the movement of test equipment and new equipment on both sides of the racks.

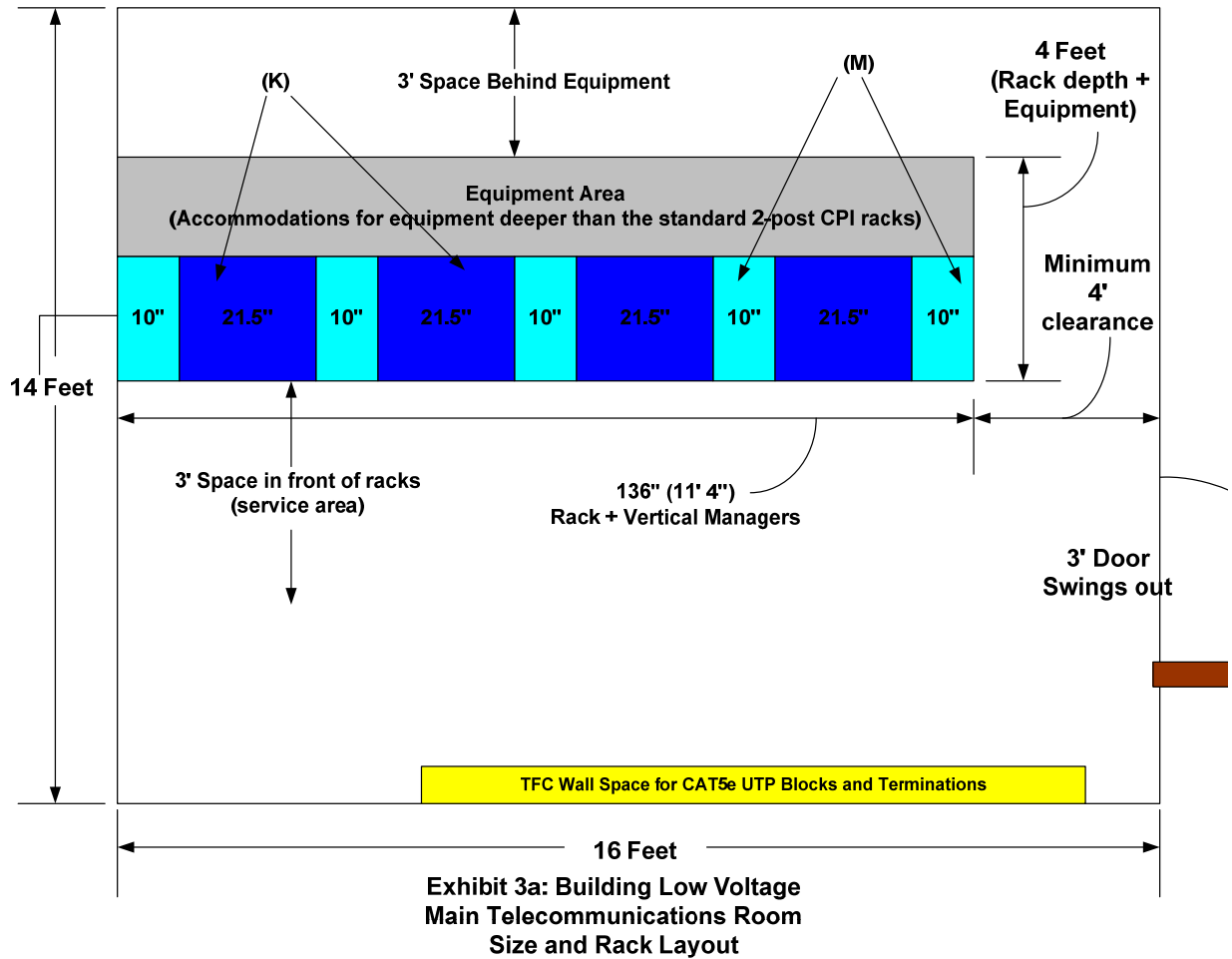
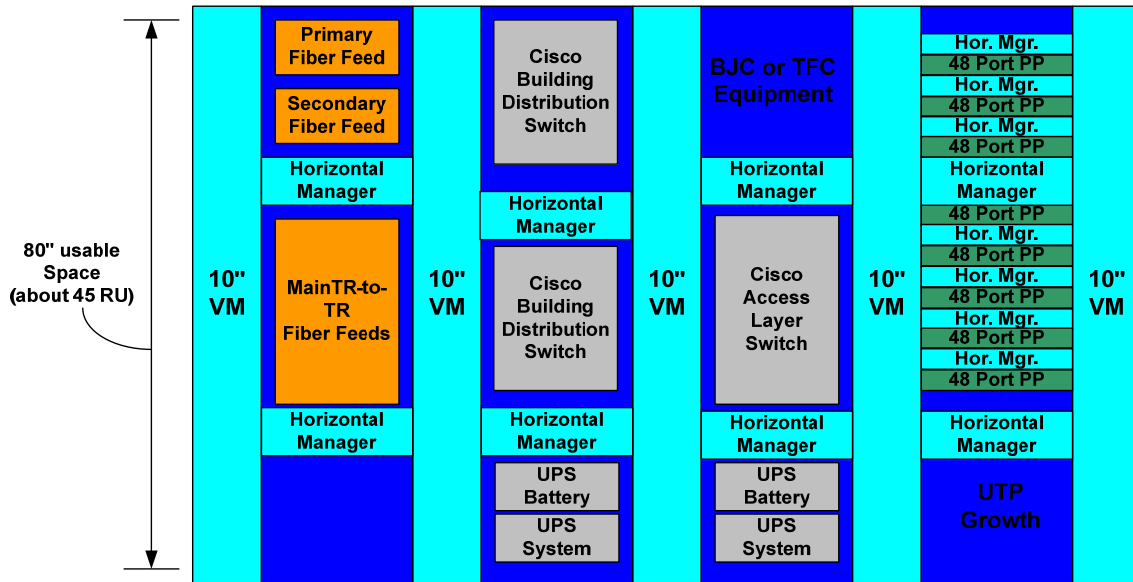

Exhibit 3b: below details the rack and equipment layout of a typical Main TR. Main TRs tend to be dense with equipment required to support voice, data, security, and other data services for all upper floors and the TR for that area. This is amplified if more than one network is required in that building. Additional floor space is required to support TFC voice equipment such as termination frames copper risers, EPN units, and UPS equipment. To ensure the proper space to support both voice and services, Main TRs should be designed with a minimum size of 14' x 16'. The following Main TR information may be useful in understanding the space requirements:

- EPNEC – 4 racks
- ML – 5 racks
- PRB – 3 racks (minimal TR requirements)
- 4444 – 4 racks



**Exhibit 3b: Building Low Voltage -
Main Telecommunications Room
Rack Layout**

Part 4b: Telecommunication Room - TR

The size requirements of any TR is based on many criteria, however, the most important of these is the number of cables terminating in the room. The following guidelines can be used to plan for TR size:

# of Lines	# Racks	# 10" VM	# Cisco Switches	TR Dimensions	Comments
1-624	3	4	1-2	9' x 12'	Standard TR
625-960	4	5	2-3	14' x 16'	Standard + 1 Rack
961-1152	5	6	3-4	14' x 18'	Standard + 2 Racks
961-1248	5-6	8	4-5	11.5' x 16.5'	Oversized

- Networks utilize 10" vertical wire management with extended fingers

Other factors to consider are:

- Other services to be hosted from TR
 - Voice (Fiber EPN)
 - VoIP
 - Building Automation
- Anticipated growth for each floor in terms of occupants or workspaces. This standard provides 10-20% growth space for future terminations in each TR.

Exhibit 3c: below details a standard 3 rack TR. A standard TR is equipped with the following:

- 1 CPI Rack (K) for Fiber Optic terminations, a Cisco switch, and UPS systems
- 1 CPI Rack (K) for UTP terminations
- 1 CPI Rack (K) for UTP terminations, WUSM, BJC, TFC, equipment, and additional UTP connections
- All CPI Racks are attached to two vertical managers.
- One clean wall on door side to accommodate TFC CAT6 voice terminations
- 4 – Series 44 EZ Path conduit (C) or “cores” (minimum) to the TR (J) below or the Main TR
- 4 – Series 44 EZ Path conduit (C) or “cores” (minimum) to the TR (J) above
- 1 – Series 22 EZ Path conduit stubs or “core” for the grounding bus
- Series 44 EZ Path conduits or cable tray from the hallway or cable pathways for the horizontal cabling
- Voice frame for backbone terminations

A standard TR should be planned and designed to include the following criteria:

- The minimum room size is 9'x 12'. This will allow the installation of 3 CPI racks (K) as detailed in Exhibit 3c:
- The racks (K) are 3' in depth including the actual rack depth plus the equipment depth. The racks should be located to allow:
 - 5' of clearance on the front, and 3' on the service side of the racks
 - 3' of clearance on the back, or termination side, of the racks
- The equipment widths are:
 - Racks – 21.25" W
 - Vertical Managers – 10" W with extended fingers
 - The total equipment length is (8' 8.5")
 - This leaves a 4' clearance to service the back of the racks and allow entry into the TR.

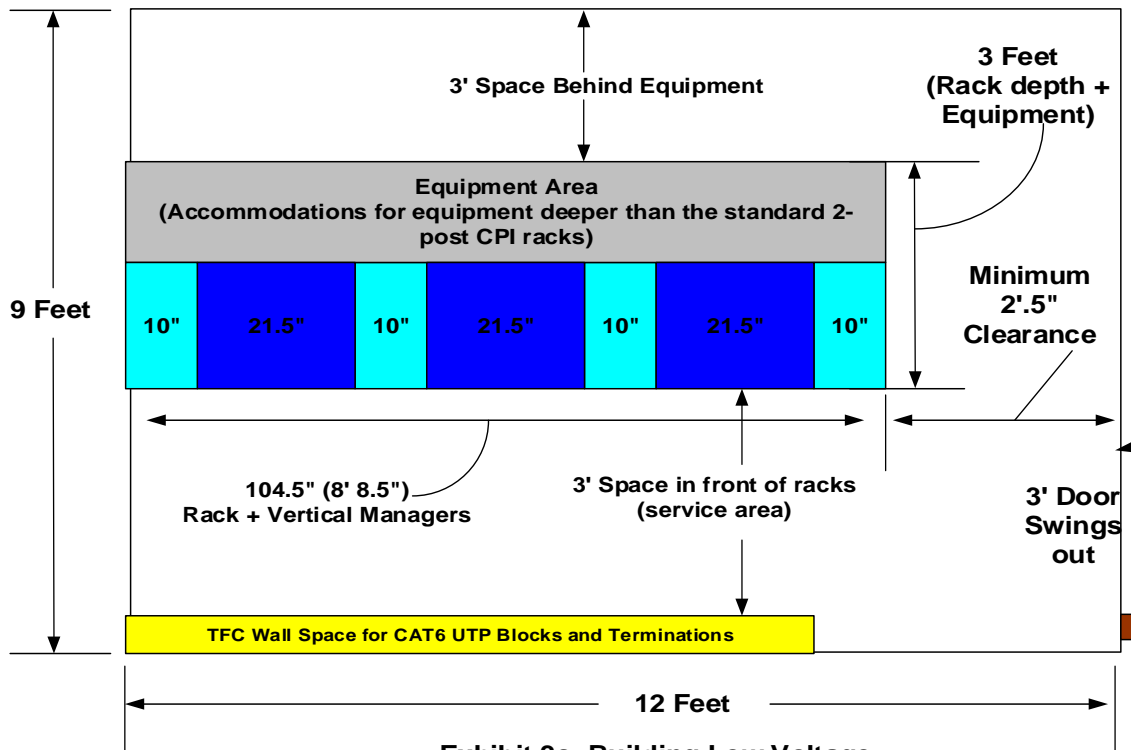
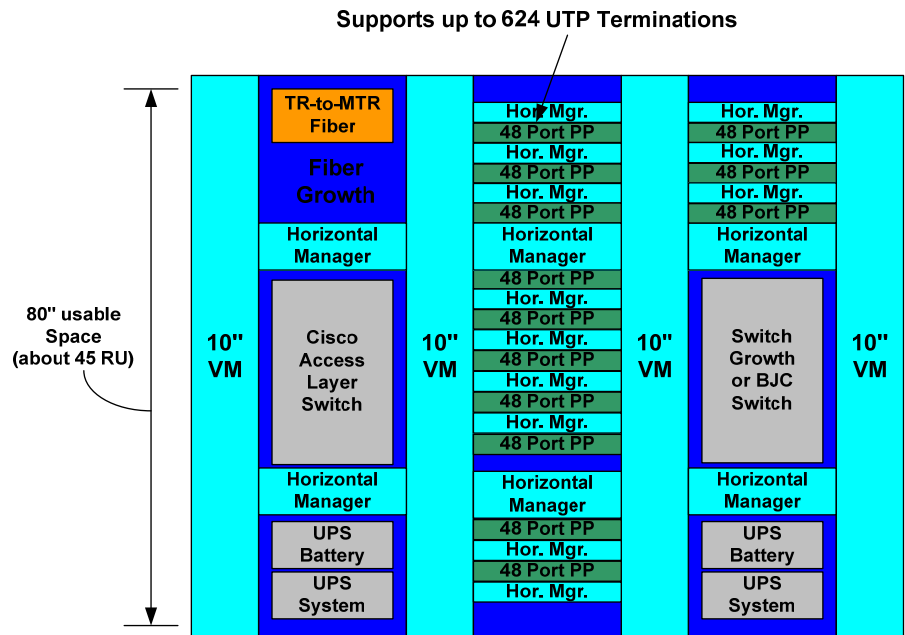
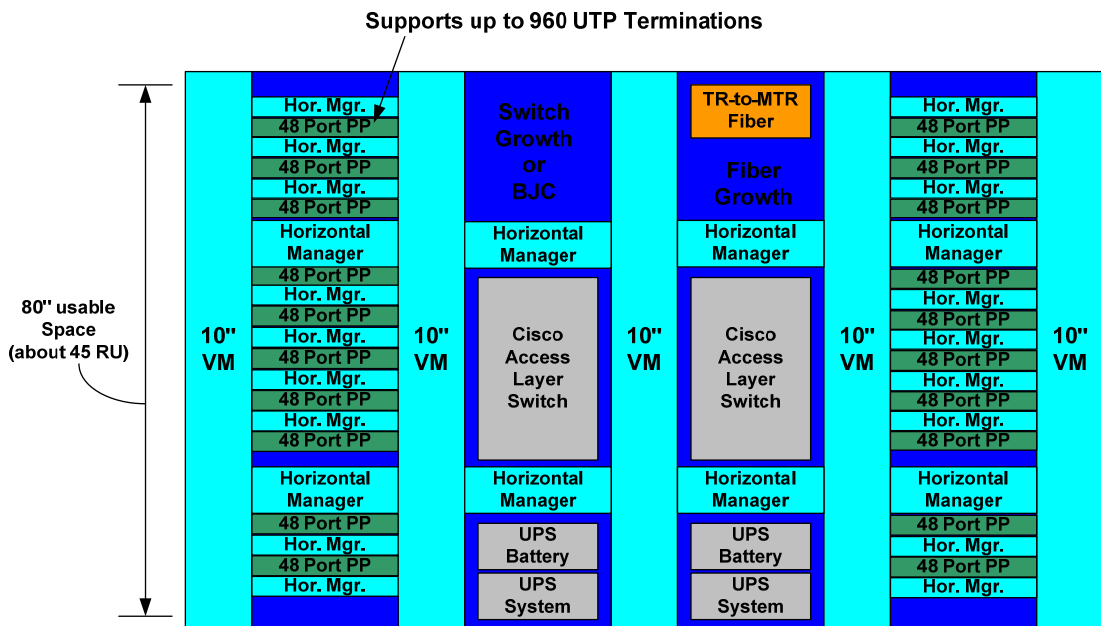

Exhibit 3c: Building Low Voltage - Telecommunications Room Standard Size and Rack Layout

The layout of the rack systems and all associated equipment may change depending on several factors such as the number of UTP terminations, number of networks supported, BJC, WUSM, or TFC presence, or the support of ancillary voice and data services. Exhibit 3d: shows the rack and equipment layout of a standard 3 rack TR. Exhibits 3e-f: show the rack and equipment layout details for all non-standard TRs.



**Exhibit 3d: Building Low Voltage -
Telecommunications Room
Standard 3 Rack Layout**



**Exhibit 3e: Building Low Voltage -
Telecommunications Room
4 Rack Layout**

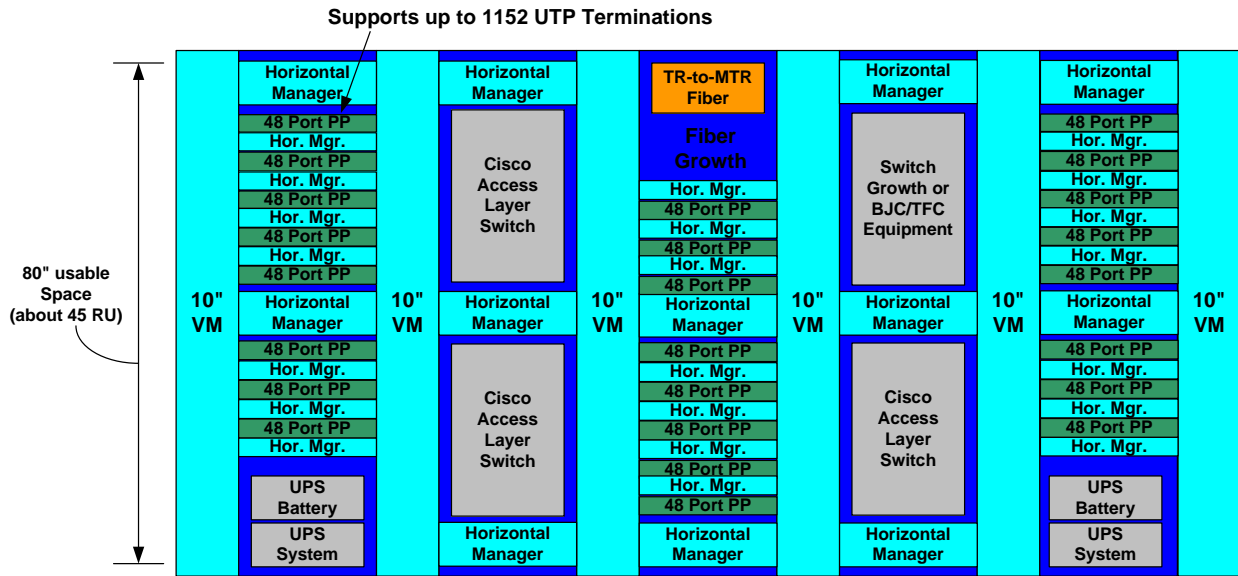

**Exhibit 3f: Building Low Voltage -
Telecommunications Room
5 Rack Layout**

Part 4c: Oversized Telecommunication Rooms

In facilities with a heavy concentration of workspaces and associated low voltage cabling, larger TRs may be necessary. Exhibits 3h: show the TR floor layout alternatives for oversized TRs consisting of 5-6 racks. While this option is rare, the design may be needed for future facilities.

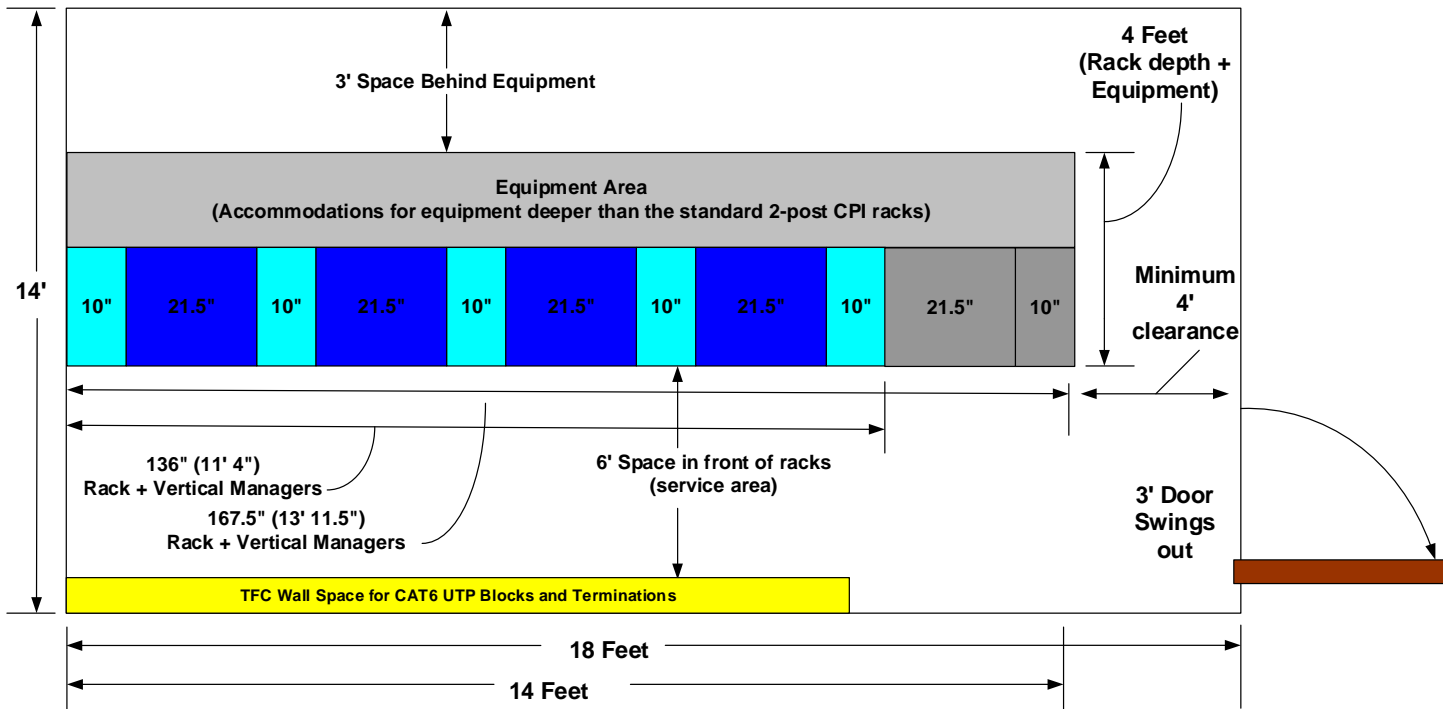

**Exhibit 3g: Building Low Voltage -
Telecommunications Room
Oversized TR Layout**

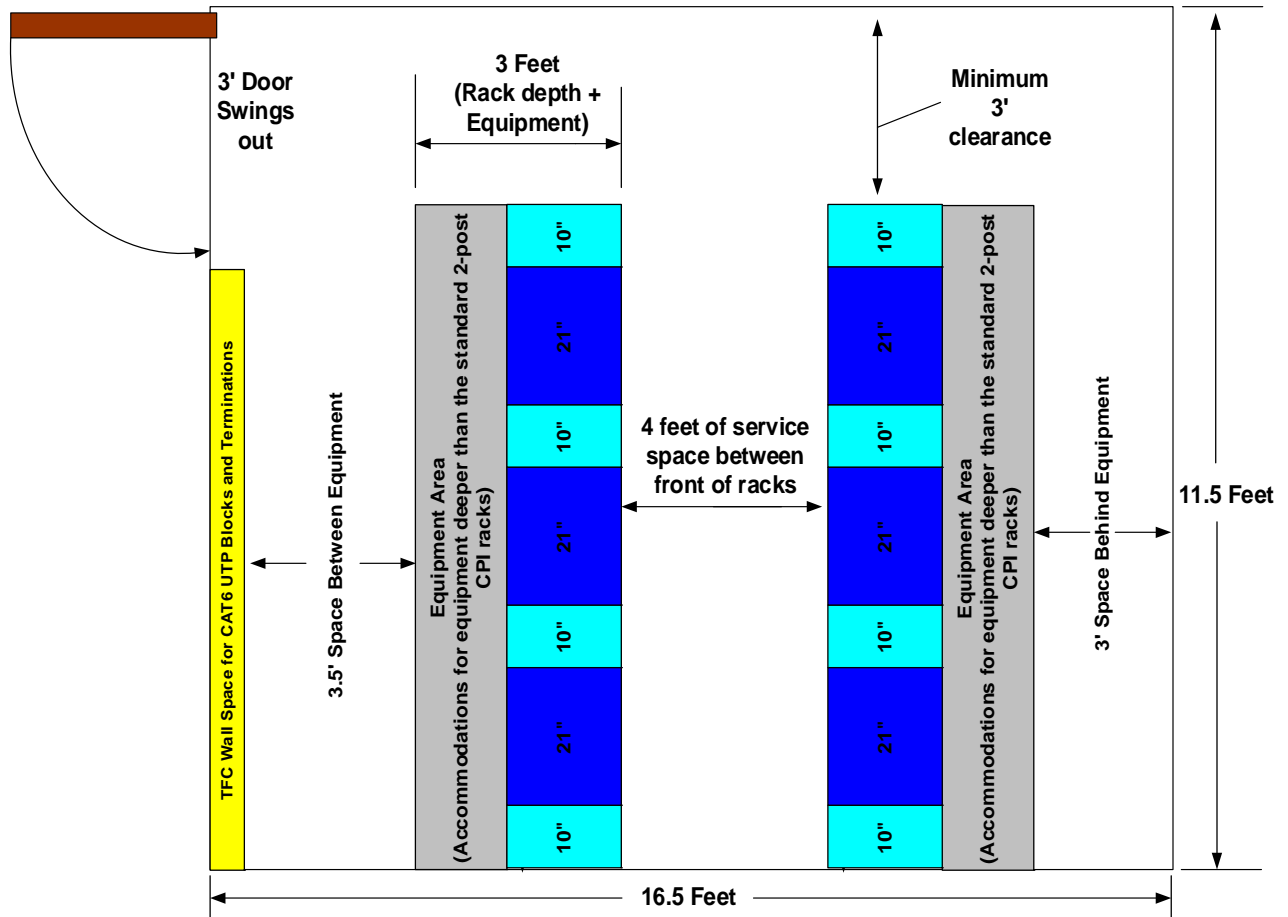

Exhibit 3h: Building Low Voltage - Telecommunications Room Oversized TR Layout (5 or 6 racks)

Part 5: Cable Tray and Horizontal Pathways

Planning and designing pathways and spaces also applies to the raceways and support systems required to run the low voltage cabling from the TR to the user workspaces, labs, auditoriums, or classrooms. How the cable is run and supported depends on several criteria. The following information is important:

- What type of horizontal cabling is being run to the workspaces? The cable type selection will have an impact on the conduit and raceway fill ratio. Fiber Optics often requires a separate pathway to prevent damage when future cables are installed.
 - CAT6 UTP – refer to Appendix G
 - Coax – can be run in the same conduit as UTP but requires 2X the space due to its diameter
 - Fiber Optics – requires innerduct or armoring; may be run separately in horizontal spaces
 - Current WUSM standard is 1 CAT6 and 1 CAT6 for TDM solutions or 1 CAT6 for VoIP solutions.
 - Current BJC standard is 1 CAT6 for VoIP solutions or additional CAT 6 for TDM solutions.
- Will there be wireless support on this floor? Wireless often requires special mounting brackets and cable terminations. Geographic surveys are required to plan for the proper location of the UTP feeds.
- In what environment will the cable be run?
 - Drop ceiling plenum space – cable tray or J-hooks, or basket tray

- Open ceiling architecture – cable tray or J-hooks, or basket tray
- Sealed or clean environment (animal space or clinical lab)
 - Requires homerun conduits to each workspace or lab bench
 - ¾", 1", or 2" conduit depending on number of cables and type
 - Number and location of ceiling access panels and pull boxes is critical to add future cables or service existing infrastructure
- Behind the wall (drywall/wallboard)
 - Requires conduit stub and wall box for new construction
 - ¾" or 1" conduit depending on number and cable type
 - for standard installation a ¾" is sufficient for CAT6
- Surface Mount (concrete or cinder block)
 - Requires a behind the wall conduit stub and wall box
 - ¾" or 1" conduit depending on number and cable type
 - for standard installation a ¾" is sufficient for CAT6
- Modular furniture
 - Make sure the modular furniture supports dual raceway structure for power and data
 - Ensure the system supports enhanced fill capacity for CAT6 installations
 - May require access to modular furniture system via columns, walls, or power/data poles
 - Do these products integrate with Panduit termination products? (Most do!)
- Lab (power/data raceway)
 - Wiremold or other dual power/data raceway system
 - ¾", 1", or 2" conduit depending on number of cables and type
 - Does the system support Panduit termination products? (Most do!)
- Auditorium (under seat or table top)
- Classroom or Conference Room (floor box or table top)
 - Fill ratio issues are abundant in this environment
 - CAT6 requires more space – see Appendix F and G for fill ratios
- How many cables need to be supported? Will the installation require cable tray (F) or J-hook supports?
 - What size cable tray is needed? In pathways that will require more than 100 6 cables, it is recommended to use cable tray. Pathways with less than 100 cables can be supported with standard 4' J-Hooks.
 - 2" D x 12" W Cable Tray – up to 260 CAT 6 UTP cables
 - 2" D x 18" W Cable Tray – up to 400 CAT 6 UTP cables
 - 2" D x 24" W Cable Tray – up to 540 CAT 6 UTP cables
 - 4" D x 12" W Cable Tray – up to 500 CAT 6 UTP cables
 - 4" D x 18" W Cable Tray – up to 750 CAT 6 UTP cables
 - 4" D x 24" W Cable Tray – up to 1000 CAT 6 UTP cables
- How will the raceway system enter the TR?
 - In most cases the best solution is having the cable tray system enter the TR and address the ladder rack system with the appropriate water falls. Waterfalls should support any cables dropping more than 12". This is most suitable for TRs supporting more than 260 lines.
 - In smaller TRs with 260 or less lines, 4" conduits can be used to stub between the hallway raceway system and the TR ladder rack system. (Refer to Appendices F and G for the 4" conduit fill ratio for CAT5e and CAT6.) The basic guidelines are:
 - CAT5e – 128 lines per 4" conduit
 - CAT 6 – 40 lines per 4" conduit
 - In larger TRs, with 260 lines or more, the appropriate sized cable tray should be run from the pathways into the TR. If more than 1000 lines are supported in a TR, two cable tray entry points may be required.
 - If fiber optic cables need to be brought into the TR horizontally; a dedicated conduit or path should be used to protect the fiber from future installations of UTP. The appropriate PM will make the decision whether or not to use Telect (WUSM) or Panduit Fiber Runner (BJC).
 - In environments where conduit is run directly to the workspace, such as animals, clean areas, etc., the TR must be designed to accommodate these feeds and address them into the TR ladder rack system.

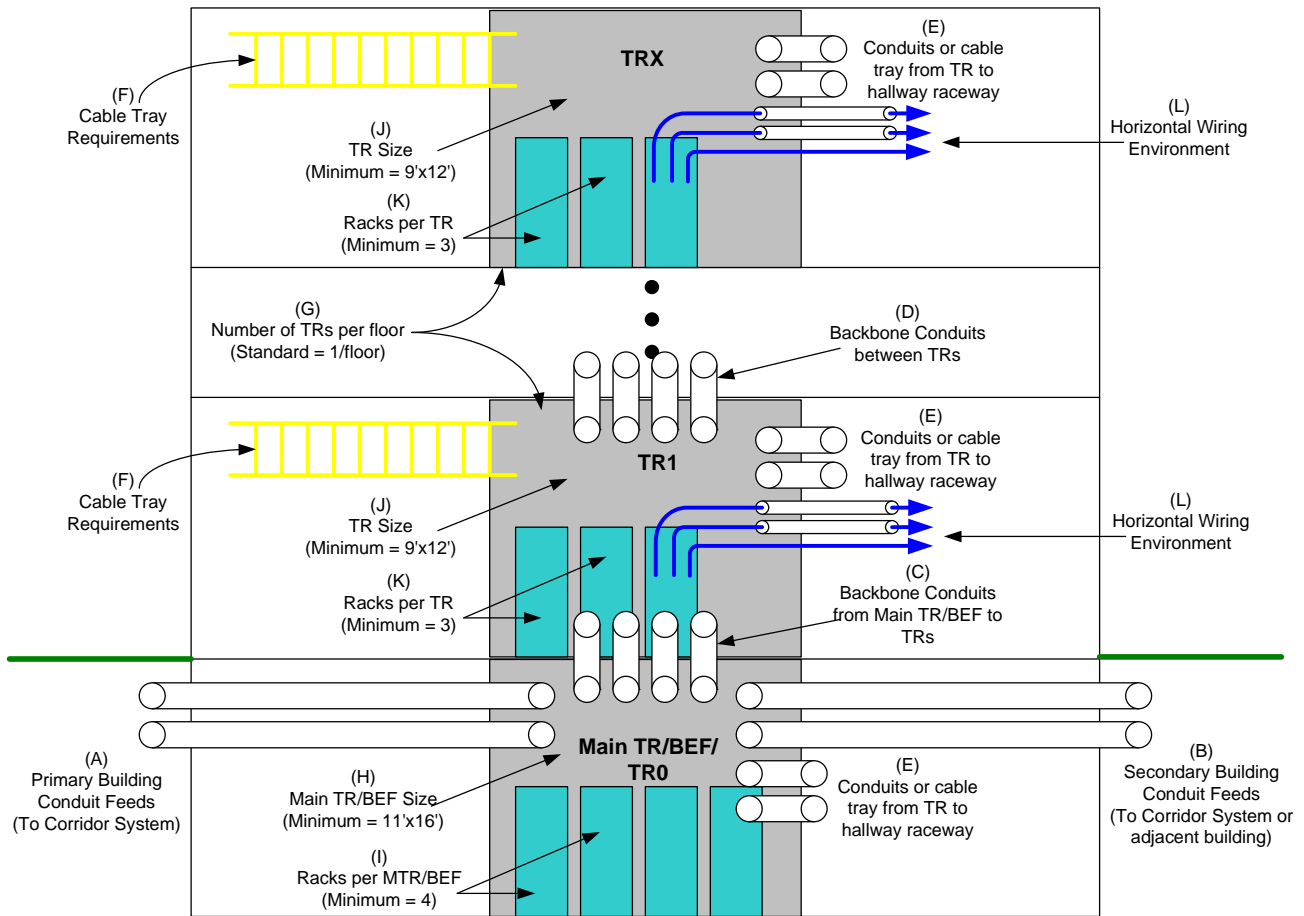

Exhibit 4a: Building Low Voltage - Pathways and Space

Part 6: Grounding and Bonding

Purpose:

This section's primary focus is to ensure the safeguard of all personnel, equipment, and property from undesired voltages and currents. This section serves as a planning guide for complying with best practices found in grounding and bonding of all existing WUSM/BJ entrance facilities (EF), and Telecommunication rooms (TR), found in new facilities, during renovations, and in existing locations found both on the WUSM/BJ Campus and off The WUSM/BJ Campus. This section is based upon information contained in the National Electric Code (NEC 70), articles 250, and article 800, and from standards ANSI/TIA/EIA-607A, ANSI/NECA/BICSI-568, and ANSI/IEEE1100 Emerald Book.

Scope:

The scope of this section is to lessen the chance of personnel injury, and damage to property due to lightning strikes, and induced voltages, to eliminate damage due to questionable grounding and bonding practices while at the same time, improving/maximizing communication and other sensitive equipment's performance. This section provides an overall specification of cable types, services, or termination equipment, it should be used for the purposes of planning and designing the appropriate grounding and bonding method for telecommunication rooms, building entrance facilities, cable tray and raceways systems, and all conduits used for low voltage voice, data, and video systems.

The purpose of a grounding system is to create a low resistance path that will carry electrical surges and transient voltages such as lightning, and electrostatic discharges to earth ground. A properly designed system is one that is visually verifiable,

sized correctly for the expected currents, and directs potentially damaging currents away from equipment. All metallic component part of the communication infrastructure such as equipment, cable trays, cabinets, racks, or blocks must be properly grounded and bonded.

Part 6 Grounding and Bonding:

Article 1: Building Single Grounding Point

Article 2: Telecommunication Main Grounding Buss Bar (TMGB)

Article 3: Telecommunication Bonding Backbone (TBB)

Article 4: Telecommunication Grounding Bussbar (TGB)

Article 5: Grounding and Bonding Building Entrance of Facilities (BEF), Main Telecommunication Rooms (MTR), and Telecommunications Rooms (TR).

Article 6: Appropriately sizing ground conductors.

Article 7: Best Practices.

Article 1: Building's Single Grounding Point:

- All WUSM/BJ building's single grounding point will be the building's electrical service ground. This results in good contact with earth ground, and results in a low resistance to ground necessary for dissipating all fault currents, lightning strikes, static discharges, electromagnetic frequency (EMF), and Radio Frequency Interference (RFI), safely into the earth.
- The bonding conductor between the building's main grounding point and the TMGB in the main TR will be sized 3/0 AWG. If it is insulated, the insulation shall be green, green with a yellow stripe, or black with green tape on a black conductor every 3 feet.
- The physical connection to the electrical service ground will be either an exothermic weld or through the use of an Underwriters (UL) 486A listed irreversible compression fitting.
- NEC section 250-92 requires an intersystem bonding connection that is accessible at the electrical service equipment ground to effectively equalize the difference of potential between the power and telecom cabling.
- All connections will be an IEEE-837 approved irreversible type compression fitting.
- All non-conductive coatings such as paint, lacquer, and other electrically non-conductive coating must be removed from surface areas where connections are to be made to ensure a good electrical connection. The use of a star washer does not satisfy the requirement to remove non-conductive coatings from attachment surfaces. (NEC 70, Article 250.12)

- The resistance from the ground system to the physical earth ground shall be 25 ohms or less, and the resistance from the protector to the ground system (equipment ground) should be less than 1 ohm. (NEC 250)

Article 2: Telecommunication Main Grounding Bus Bar (TMGB)

- The Telecomm Main Grounding Bussbar serves as an extension of the building ground point for the purpose of grounding the telecommunications infrastructure.
- The TMGB provides a central attachment point for all of the building's TBBs. The TMGB will be bonded to building steel and grounded / earthed to the electrical service ground according to J-STD-607-A guidelines.
- The TMGB will be found in the building's Main Telecommunications Room (TR). The main TR may or may not be the building's Entrance Facility (EF). The bonding conductor will be directly attached between the building's single ground point, normally the electrical service ground at the building's entrance, and the building's main TR.
- The bonding conductor between the building's main grounding point and the TMGB in the main TR will be sized 3/0 AWG. If it is insulated, the insulation shall be green, green with a yellow stripe, or black with green tape on a black conductor every 3 feet.
- Use a TMGB (see Appendix O) that is UL listed, 4"W x 1/4" H x 20" L, accepts 2-hole lugs, and whose stand-off bracket is made of 300 series stainless steel. Mount the TMGB approximately 18" above the floor or if fire rated plywood is installed, at the bottom of the plywood, which is approximately 18" above the floor.
- All busbars will be positioned near associated equipment, insulated from its support, and be capable of safely carrying lightning and powerful currents. Before a mechanical connection is made, the attachment area should be thoroughly cleaned prior to fastening of conductors. Apply anti-oxidant to the tongue of the connector before the bonding connection is made in order to reduce corrosion and contact resistance.
- All connections to the TMGB will be made through the use of UL listed 2-hole, irreversible compression lugs. Use appropriately sized Panduit Corp. LCC-W type lugs, no substitutions.
- Ground bus conductors must maintain a 2" separation from all other electrical and communication wiring. An exception may be when conductors are grouped together to enter or exit a cabinet or enclosure.
- Ensure that the fault current will flow in the direction of the ground bussbar by increasing each successive ground conductor leading to the ground bussbar by one gauge size from the previous one.
- A TGB will be located in each telecommunications space. The TGB will be grounded / earthed to the TMGB.
- All grounding conductors between the building's single ground point, TMGB and all Telecom grounding busbars (TGB) will be physically secured.

Article 3: Telecommunication Bonding Backbone (TBB)

- The TBB's intended function is to equalize or reduce potential differences in the telecommunication system's grounding and bonding infrastructure. The TBB may carry some AC power current, but its intent is not to be the only ground fault return path.
- In multistory buildings, the TBB will be a continuous 3/0 AWG backbone cable from the TMGB to the farthest TGB. Typically, the TBB will connect all Telecommunication grounding bussbars (TGB) normally found in the building's Entrance Facility (EF), and in all Telecommunication Rooms (TR). When more than one TBB is used bond them together using the TGBs on the top floor and every 3rd floor in between, with a conductor known as the grounding equalizer (GE)

- The TBB may be insulated, but if insulated, it will meet the fire rating of its pathway. The TBB normally will be installed without splices, but if splices are required, splices shall be exothermically welded or an irreversible compression type connector will be used.
- All connections to the TBB must be physically accessible, visually inspectable, and be made with irreversible compression fittings or be exothermically welded.
- Grounding and bonding conductors should not be placed in ferrous metallic conduit. If it becomes necessary to place grounding or bonding cable in a metallic conduit that is longer than 3', the conduit shall be bonded at each end with a grounding bushing or a minimum of a #6 AWG bonding conductor. Use appropriately sized Panduit series GPL and Panduit part number series HTCT.
- Ground buss conductors must maintain a minimum bend radius of 8". The angle of any bend must not be less than 90 degrees. Never coil ground buss conductor upon itself.
- Ground buss conductors must maintain a 2" separation from all other electrical and communication wiring. An exception may be for when conductors are grouped together to enter or exit a cabinet or enclosure.
- Ground conductors may be green, green with a yellow stripe, or black with green tape on a black conductor every 3 feet.
- The TBB and TGB must be visibly inspectable, and physically secured.

Articles 4: Telecommunications Grounding Busbar (TGB)

- The TGB serves as the single grounding and bonding point for all telecommunication systems and equipment located in that particular location's TR or ER.
- The TGB will be UL listed 4"W x ¼"H x 12"L, accept 2-hole lugs, and the isolation stand-off bracket will be made of 300 series stainless steel.
- All connections to the TGB will be made through the use of UL listed 2-hole, irreversible compression lugs. Use appropriately sized Panduit Corp. LCC-W family type lugs, no substitutions.
- Each Telecommunication back bone (TBB) that bonds a Telecommunications ground bussbar (TGB) to the building's Telecommunications Main Ground Busbar (TMGB) must be bonded with UL listed irreversible compression fittings, or be exothermically welded.
- Every TGB will be horizontally bonded to the nearest electrical panel ground with a #6 AWG appropriately colored bonding conductor. Use appropriately sized Panduit Corp. LCC-W family type lugs at TGB, no substitutions.
- Each TGB will be directly bonded to building structural steel if building structural steel is readily available with a #6 AWG appropriately colored bonding conductor. Use appropriately sized Panduit Corp. LCC-W family type lugs at TGB, no substitutions.
- Ground bus conductors must maintain a 2" separation from all other electrical and communication wiring. An exception may be when conductors are grouped together to enter or exit a cabinet or enclosure.
- The TBB and TGB must be visibly inspectable and physically secured.

Article 5: Grounding and Bonding Building Entrance Facilities (BEF), Main Telecommunication Rooms (MTR), and Telecommunications Rooms (TR)

Note: NEC Article 100 defines bonding as the permanent joining of metallic parts to form an electric path that will ensure electrical continuity and the capacity to safely conduct away any current likely to be imposed.

- In normal conditions, the building's entrance facility (EF) will contain the TMGB. All telecommunication rooms (TR) and all equipment rooms (ER) will contain a TGB.
- All TGBs connected to the building's TMGB through the TBB, must be bonded on the TBB side with UL listed irreversible compression fittings, or be exothermically welded. On the TGB side, all connections will be bonded with UL listed 2-hole irreversible compression lugs. Use appropriately sized Panduit Corp.LCC-W family type lugs, no substitutions.
- The TGB will be bonded horizontally to the nearest electrical panel ground using a #6 AWG bonding conductor insulated green.
- Bond the TGB horizontally to building steel, if building steel is available, with a #6 AWG bonding conductor insulated green.
- All TRs and ERs, and EFs that serve dual purposes as a TR or EF, will have a #2 AWG green insulated continuous grounding conductor installed around the perimeter of the room.
- Install a section of perimeter ground parallel to each row of rack
- Attach the perimeter #2 AWG insulated green bonding conductor to the outside of the ladder rack with L brackets for support. Ensure that a two inch separation from any other installed cabling is maintained.
- Both ends of the #2 AWG insulated green grounding conductor will be bonded to the room's TGB with an UL listed 2-hole irreversible compression lugs. Use appropriately sized Panduit Corp. LCC-W family type lugs, no substitutions.
- Install supports approximately every 18" to support the #2 AWG perimeter grounding conductor.
- Bond ladder rack at each mechanical connection splice using a #6 AWG jumper across each mechanical connection, i.e. joining of two pieces of ladder rack. No grounding, bonding, or electrical cables will run through the ladder rack.
- Install a 19" grounding bussbar that accepts 2 hole grounding lugs ground conductors in the top of each network rack/cabinet on back side that will contain equipment. The bussbar needs to be connected to the perimeter grounding conductor with an irreversible compression fitting (H-Tap).
- If required, a vertical buss bar is used to accommodate grounding for the rack and the contents. The vertical buss bar will be installed in the vertical wire managers on each side of the rack. When the vertical buss bar is used the horizontal buss bar is eliminated from that rack.
- All non-conductive coatings such as paint, lacquer, and other electrically non-conductive coating must be removed from surface areas prior to making a physical connection to ensure a good electrical connection can be made. The use of a star washer does not satisfy the requirement to remove non-conductive coatings from attachment surfaces. (NEC 70, Article 250.12)
- Prior to making a bonding connection, thoroughly clean the attachment area. Apply anti-oxidant to the tongue of the connector before attachment to the contact area in order to prevent corrosion and reduce contact resistance.

Article 6: Appropriately sizing ground conductors.

- From building electrical ground to main entrance facility/telecommunication room's main grounding bussbar: 3/0 AWG bonding conductor.
- From the telecommunication main grounding bussbar, the telecommunication bonding backbone: 3/0 AWG bonding conductor.
- From the telecommunication backbone to each TR/ER grounding bussbar: 3/0 AWG bonding conductor.
- From each telecommunication room's grounding busbar, the bonding conductor run around the perimeter of the room: #2 AWG bonding conductor.
- From the #2 AWG bonding conductor to each equipment rack busbar: #6 AWG bonding conductor.
- From the #2 AWG bonding conductor to the room's bonded ladder rack: #6 AWG bonding conductor.
- Across every mechanical connection: #6 AWG bonding conductor jumper.

Article 7: Best Practices.

- All grounding and bonding connections will be made with UL listed irreversible compression fittings or be exothermically welded. All lugs used in conjunction with grounding conductors will be UL listed, 2 holed, and double crimped. Use appropriately sized Panduit Corp. LCC-W family type lugs, no substitutions.
- All grounding and bonding conductors will be as short as possible.
- All attachment areas will be thoroughly cleaned prior to the fastening of bonding conductors. Before attachment, an antioxidant will be applied to the contact area to reduce corrosion and contact resistance.
- All mechanical connections will have non-conductive coatings removed from the attachment surfaces. The use of a star washer does not satisfy this requirement. Apply anti-oxidant to the connector before attachment to the contact area reduce corrosion and contact resistance.
- Before bonding metallic raceway/equipment racks, apply a generous coating of antioxidant joint compound to the mating surfaces to reduce corrosion and contact resistance.
- Ground bus conductors must maintain a 2" separation from all other electrical and communication wiring. An exception may be when conductors are grouped together to enter or exit a cabinet or enclosure.
- Ground bus conductors must maintain a minimum bend radius of 8". The angle of any bend must not be less than 90 degrees. Never coil ground bus conductors.
- Grounding conductors should be kept as short as possible.
- No Grounding, bonding, or electrical cabling will run through ladder rack.

Appendix A: Grounding and Bonding Abbreviations Terms and Abbreviations.

- Telecomm Main Grounding Busbar : **TMGB**
- Telecomm Bonding Conductor: **TBC**
- Telecomm Bonding Backbone: **TBB**
- Telecomm Grounding Busbar: **TGB**

Appendix B: Telecommunication Terms and Abbreviations.

- Entrance Facility: **EF**
- Telecommunications Room: **TR**
- Equipment Room: **ER**

Appendix C: Building Grounding and Bonding Diagram.

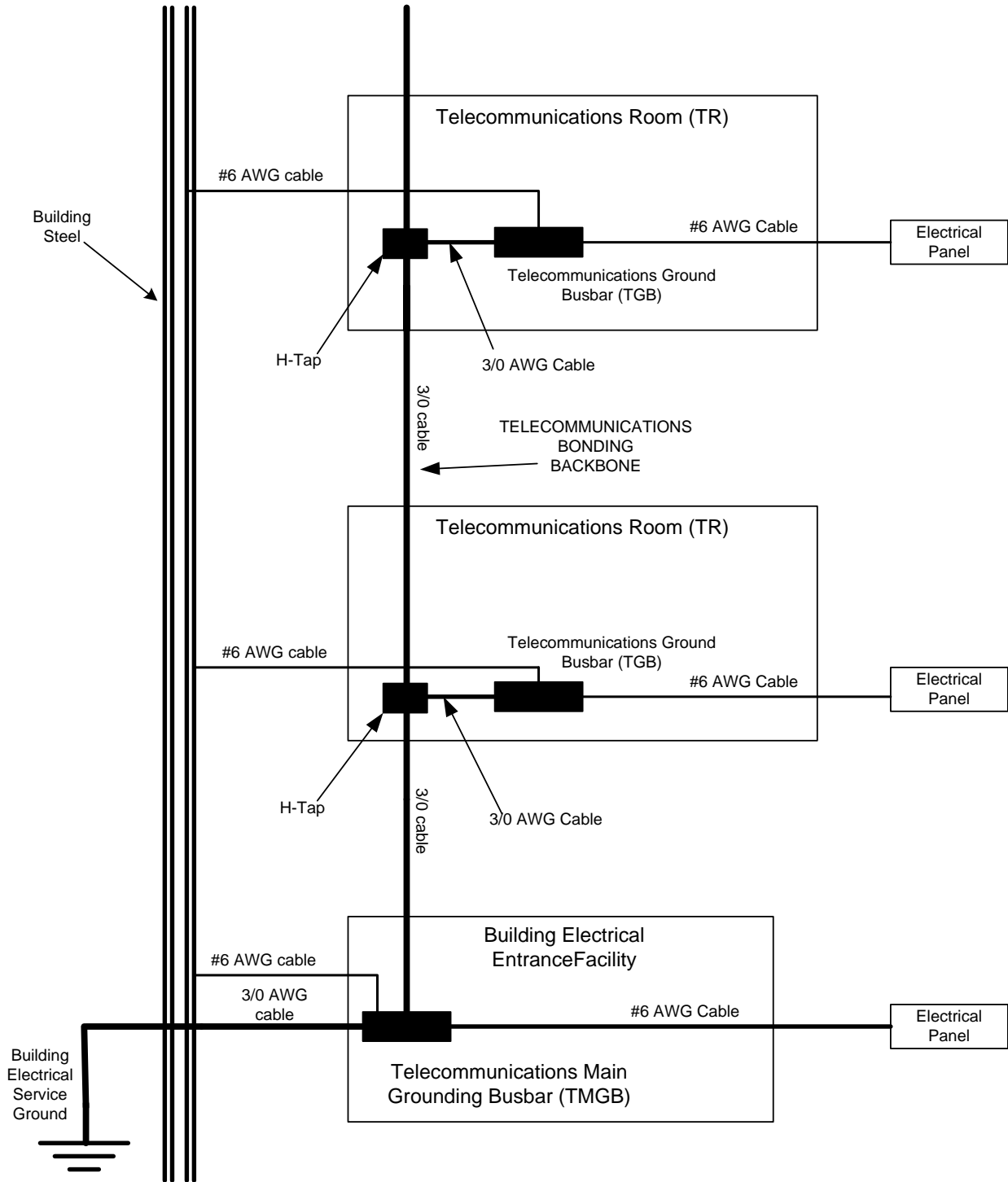

Updated 9/21/06 MLK

Appendix D: Telecommunication Room Grounding and Bonding Diagram.

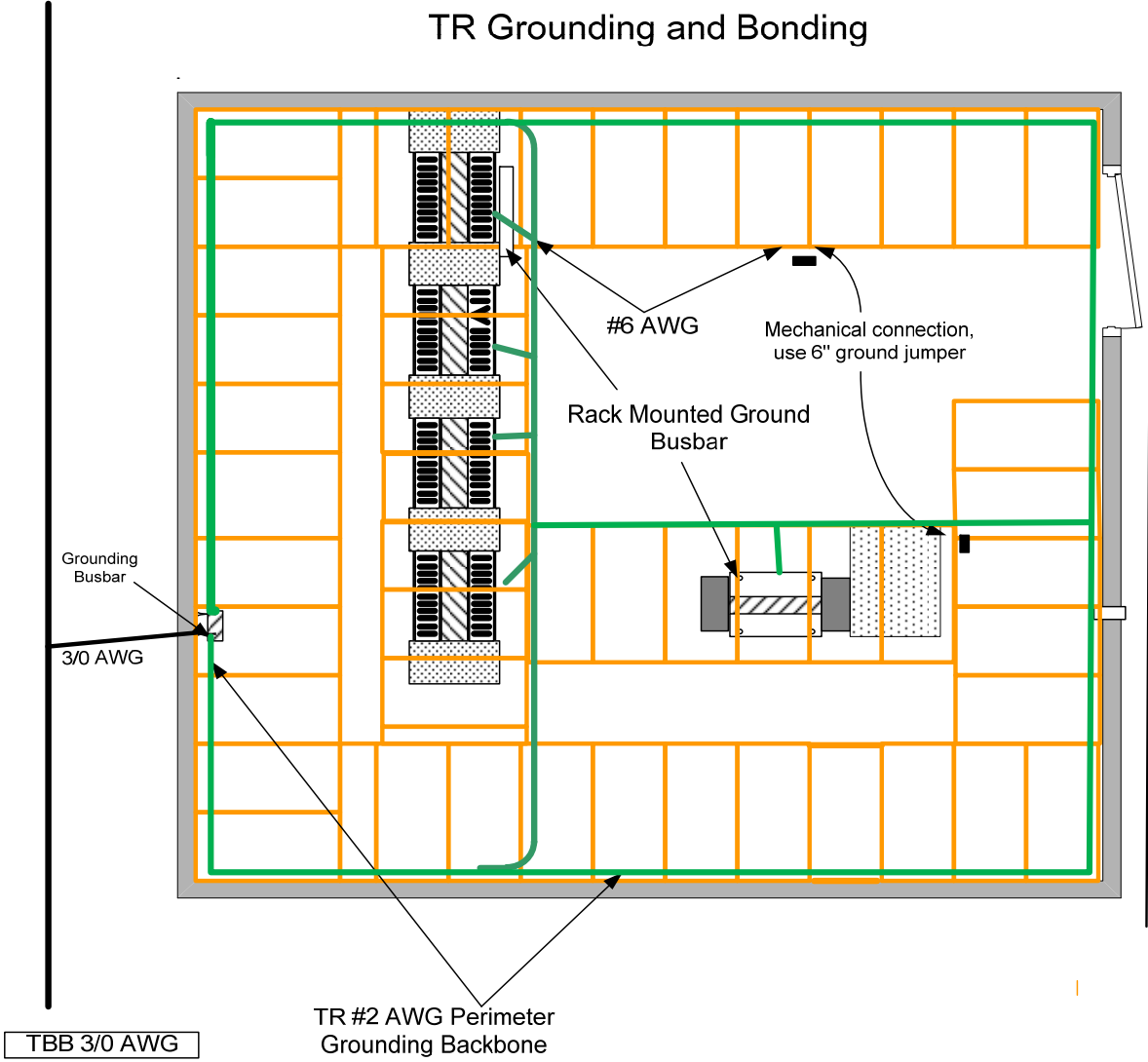

Part 7: General Information

Part 7a Data Equipment Racks:

- All equipment racks will be Chatsworth Products Inc., 19" by 84" (unless otherwise specified) Black in color. Occupant (BJ/WUSM/TFC) will determine rack size, and the total number of racks.
- Racks will be securely mounted to the floor using ½" lag bolts. In raised floor applications, ½" threaded rods will penetrate the floor plate and be secured directly into the concrete flooring below the access space. Appropriate nuts for the size rod will support both the rack-supporting frames from above and below the floor plate. Threaded rod will be cut off 3 threads above the nut.
- Install an 18" or 24" wide, UL Classified, overhead ladder tray in the Main TR and TR. Secure the ladder tray to the top of each rack using 6" cable runaway elevation kit. In a typical TR room, the tray should be a minimum of 12" wide. Overhead trays will be black in color and supported on each end at the wall using adequate angle supports. If a perpendicular overhead tray is required it must be supported on one end with appropriate wall angle supports. On extremely long cable tray runs, or where wall anchoring is not possible, threaded rods will support the tray, anchored directly into the ceiling deck or pan. Additional curved runaway, horizontal radius and end/angle clamping may be required to facilitate odd room sizes and ceiling heights of conduits.
- In TRs install a dual layer of ladder rack. The first layer should be 6" above the top of the data racks. Ensure that the two layers of ladder rack maintain a 12" vertical separation between one and another. When utilizing a dual ladder rack installation, install the telecommunication room's perimeter ladder rack at the same height as the upper row of ladder rack. Station cable will utilize the upper row of ladder rack before landing on the back side of the data racks. The feeder fiber and copper cable will utilize the lower ladder rack. Cross-connect cabling will utilize the lower row and land on the front side of the data racks. The appropriate project manager/analyst will make the decision whether or not to utilize a dual ladder rack installation.
- Install all mating surfaces of both racks and tray, and supporting hardware in such a manner as to allow adequate grounding. Bonded jumper wire may be required and should be mounted to the back of the rack so as to not interfere with machined screw holes for front loading equipment towards the bottom of the rack. Removal of anodized coating or paint will occur at each mating surface.
- In all data racks, signal cabling will be installed on the front of the rack, and power and grounding will be installed on the back side of the racks. The appropriate owner (WUSM, BJC, or TFC) will determine which side will be the front side of the rack for each installation. If the wall space is limited contact the appropriate owner (WUSM, BJC, or TFC).

Part 7b Voice Equipment Racks:

- Unless specified all backbone, feeder and horizontal cable will terminate on analyst specified wall mounted frames, size to be determined by feeder count, station count, and future expansion. The frames are fitted with 89B brackets and 66M blocks. Blocks will be clearly marked with indelible ink to denote cable pair number or jack ID.
- The area above the frames should be clearly marked with cable name and count, in the case of riser or feed cable or building and floor # if the frame is used for horizontal cable. All labeling should be black on white and machine typed.

Part 7c Room Layout: TR

- Create a positive pressure in the TR. (5 to 10 CFM above the exterior hallway)
- Refer to drawing exhibit 3c of this document for a typical installation layout. Any modifications due to room dimensions will need approval of the appropriate owner's data communications analyst/project manager.

- Install Data Racks within the room adjacent to a wall where possible. Installation shall occur so that a minimum of three feet clearance in the front and five feet clearance in the back is provided from the upright portion of the racks. Cable tray shall either be centered or offset from the centerline of the racks. On the perimeter Cable runway at each corner there should be a 4 - 6" Cable retaining post 5" apart in each direction from the center of the corner.
- Mount frames for telephone riser and horizontal cable on a clear wall, with a minimum of three feet clearance in front of wall frames. Frames should be placed so that backbone cable is to the extreme left of the wall. D-Rings should be mounted to provide a path for horizontal cable from the cable tray to the frames. Horizontal cable should always be fed from the bottom.
- Fire Rated Walls above the ceiling space, centered above the overhead tray, series 44 EZ Path conduits will be placed to penetrate the ceiling space of the outside hallway. Existing conduits containing cabling will be sealed with appropriate fire protection putty or EZ Path Conduits in order to maintain hour rating of the wall. The minimum number of EZ Path Conduits will be two with an optimum of four depending on location density of the floor in question.
- When more than one floor is serviced by a TR, horizontal distribution EZ Path Series 44 should penetrate the floor into the ceiling space of floor below then penetrate the ceiling space of the nearest hallway below using EZ Path Series 44. The core drills for the EZ path should be positioned in a manner to utilize unusable floor space of the TR footprint and not interfere with rack placement, door closures and work space on either side of the rack. A minimum of two should be in place.
- For floors above the TR, the conduit should penetrate the ceiling above and through continuous piping access the ceiling space of the floor. While remaining a continuous pipe, 90 degree bends should take the route to the nearest hallway ceiling space and terminate. The vertical conduit should have studs and drywall covering in user spaces but can remain exposed piping in mechanical, electrical or service rooms.
- Address all power requirements on a per situation basis and separate drawings and specifications will be given by the owner at the time of the project. Utilize Appendix I as the guidelines. Owner will determine each location's specific requirements.
- Cover all walls with (3/4") three quarters inch, Underwriters Laboratory approved fire-retardant plywood with a maximum distance off the floor of 22 inches. Cover all walls with fire-retardant, neutral color, light reflective, paint. When plywood is painted, the "Fire Rating Stencil and Underwriters Laboratory seal" on the plywood should be taped over and the tape removed after painting, so as to clearly display the rating and seal on the plywood.
- Ceilings are required if the walls do not extend and seal to the deck above. As long as the room is sealed there is no ceiling required. Ceilings will be finished with materials that are permanent in nature and will not deteriorate over time. This is to eliminate any possibility of residue from falling into or onto any equipment in the room (TR). Any finish used, should have as many light reflection characteristics as possible. When drop ceilings are installed, the ceiling grid should be installed at a height of at least 1 foot above the top of the cable trays to allow for adequate work clearance. All EZ Paths Conduits should be installed below ceiling grid to allow cables to drape directly into cable tray utilizing waterfalls if necessary.
- Telecommunication room floors should be finished with tile. Finish should be light in color and have as many light reflection characteristics as possible.
- Fluorescent lighting should be installed in each TR, Main TR, and BEF. Lighting will be mounted overhead on the ceiling and to the extent possible, high on the walls around the room to ensure the highest degree of visibility when servicing equipment. Install overhead fluorescent lighting so it does not interfere with overhead cable racks.

NOTE: All electrical and ground wire should be in the back of the vertical wire manager. All signal cable will be installed in the front side of the wire manager.

Part 7d Data Wire Management:

- Install horizontal and vertical wire management in a minimum configuration at the time of the rack and tray installation in accordance with exhibits 3a-g: of this document.
- Vertical wire management part numbers will be taken from Chatsworth, MCS Master Cabling Section, black in color. In equipment rooms where space is limited, appropriate Chatsworth MCS Master Cabling Section, vertical management, black in color will be used. (Consult with appropriate Data analyst for specifications.)
- For vertical wire management not located within a rack system, vertical wire managers shall be ladder rack installed from floor to ceiling and have 6” of standoff from the wall. As wires transition from conduit, EZ path, horizontal ladder rack or basket tray, support must be given on the cable from the transition to the vertical ladder rack. Secure all cables to vertical ladder rack via Velcro straps, every 12 inches, to reduce strain on cables.
- Leave a 1” gap between the wire management and adjacent wall to allow the management cover’s removal and replacement.
- **DO NOT use vinyl wire ties within the TR for individual cable bundles.** Black Velcro straps will be used to bundle wires. Vinyl wire ties are acceptable only to support fiber innerduct and armored fiber cable to the overhead tray. Cable support within raceways will be described in the Data Cabling portion of this document.
- On initial installation of the rack, install one 48 port patch panel, black in color at the extreme top of the cabling rack(s) to align with the first rack space opening of the vertical wire manager. Horizontal management will be installed directly below the 48 port patch panel. Additionally, one horizontal wire management will be installed at the centerline of each equipment rack, as well as one horizontal wire management below the fiber patch panel. On equipment racks where no fiber patch panel is initially installed, leave sufficient space to accommodate one in the future. Mount the horizontal wire management just below that opening. Contact the appropriate owner (WUSM, BJC, or TFC) for the placement and size of the horizontal wire managers.
- Locations where only two racks are installed or where more than three racks are installed will be handled on a case by case basis but will follow the same standards as listed above. (Consult with appropriate data analyst for specifications)

Part 7e Data Cabling:

All armored cable will be grounded at each end

- In new building construction the cabling choice is a Belden end to end solution. The jacks and patch panels will be a Belden keystone solution.

The standard for WUSM is 1 CAT6 for new buildings. The standard for BJC is 1 CAT6. In VoIP installations the standard for WUSM is 1 CAT6. The standard for BJC is 1 CAT6 for each data device. A voice device can share a data device connection. Consult with appropriate data analyst or project manager for specifications.

- Total length of data cable from termination to termination should never exceed 295’. On extreme, pre-approved runs in excess of 295 feet, a yellow modular jack will be terminated on both ends.
- All data cable will be terminated to the EIA/TIA 568B spec. In some instances where adhering to existing conditions, the cable will be terminated 568A on both ends. 568A is the exception, not the rule.
- For instances where neither end of the cables terminate within the TR/MTR (point to point installs), these pulls will be terminated with a violet color jack.

- Install all cabling so that the blue cable jacket terminates within the Jack itself and no bonded pairs are exposed. At the far end of the cable, 5-6 inches of slack should exist within the wall box to relieve strain and allow for repair within the wall box if necessary. Where possible, a loop of 15 feet of cable should be left at the ceiling to facilitate future moves or repairs. Areas where this is not practical will be reviewed on an individual basis.
- Terminations within the TR will occur in the 24 port or 48 port patch panel. Cabling numbering will be installed from left to right using the next available slot within the patch panel. The location within the patch panel will determine the ID number portion of the cable identification labeling. Horizontal wire management in both front and back shall feed both up and down for each patch panel and adequate slack should be left to allow stress relief and access to future ports within the patch panel.
- All cabling shall be run in such a manner that bundles appear straight and pleasing to the eye within the raceways and cable trays. No cables should twist around another and you should be able to follow with the eye a cable from ceiling penetration to patch panel.
- Refer to the labeling section of this document (Appendix E) for Face Plate labeling.
- Always leave an appropriate pull string with any cable along its main cable pathway through the building. Separation of the pull string to facilitate shorter runs must have another pull string inserted and secured to the end of the original pull string which had been cut to ensure full hallway and runway coverage.
- Each installed data cable must be accompanied with a softcopy and CD of tested responses of various frequencies on each pair and must fall within the acceptable range of the corresponding category level. Each test response will have the corresponding cable name printed on it for quick reference.
- Deliver a minimum of four copies of clear and accurate handwritten red-line drawings to the respective voice and data owners a minimum of 3 weeks, preferably 4 weeks, before move in date or as dictated by the respective owner.
- On the far end of the cable, the jack will terminate within a four module space, single gang sloped faceplate. The IS Project Manager in charge of the project should be contacted to verify the color of the faceplates to be used. The jacks will remain the color as specified in the standards. Data cables will terminate in the lower two slots from left to right with the top space reserved for voice cabling. Any unused positions within the faceplate will be covered with the appropriate blank insert. If more than 4 cables terminate within the same faceplate, the 2 Port, 1/3 inserts will be used allowing up to six terminations
- Category 5e cable specifications:
 - All Cat5e data cabling will be blue Belden Data Twist DT350 unless otherwise specified by the owner.
 - All Cat5e data cabling terminations will use Orange color jacks.
- Category 6 cable specifications:
 - All Cat6 data cabling will be blue Belden Data Twist 600e unless otherwise specified by the owner.
 - All Cat6 terminations will use blue jacks unless otherwise specified.
- Category 6a cable specifications
 - All Cat6a data cabling will be blue Belden Data Twist unless otherwise specified by the owner.
 - Cat6a terminations will use black jacks unless otherwise specified.
 - Cat6a data cabling shall be dressed in a fanned out manner to reduce the possibility of alien cross talk.

Part 7f Voice Cabling:

- In new building construction the cabling choice is a Belden end to end solution. The jacks and patch panels will be a Belden keystone solution.
- In the TR where Cat 5e is installed, upgrade to Cat 6 as the cable of choice going forward.

- The standard for WUSM is 1 CAT6 for new buildings. The standard for BJC is 1 CAT6. In VoIP installations the standard for WUSM is 1 CAT6. The standard for BJC is 1 CAT6 for each data device. A voice device can share a data device connection. Consult with appropriate data analyst or project manager for specifications.
- Vertical voice cable will be backbone riser rated, white in color; plenum rated when necessary to meet air space designation within the pull zone. Backbone sizes are subject to job specifications for the required project and will be specified during the bid process for that particular project. All vertical cable will originate from the Main TR of that particular location. Cable will be tested for opens, grounds or shorts and any defective pairs corrected prior to turn over.
- Horizontal voice cable will be Belden Data Twist DT350, white in color. Cat 5e will be used in voice only TRs. Cables should be tested with a four-pair tester for continuity.
- Install all cabling so that the blue (white for voice) cable jacket terminates within the Jack itself and no bonded pairs are exposed. At the far end of the cable, 5-6 inches of slack should exist within the wall box to relieve strain and allow for repair within the wall box if necessary. Where possible, a loop of cable should be left at the ceiling to facilitate future moves or repair. Distance requirements of 295 feet must never be exceeded, but the loop (not to exceed 15 feet) should allow for movement of the cable anywhere within the room in question if needed. Areas where this is not practical will be reviewed on an individual basis.
- At the user side, the voice cable will terminate within an ivory Jack. Faceplates will be four ports, single gang and sloped. The IS Project Manager in charge of the project should be contacted to verify the color of the faceplates to be used. The jacks will remain the color as specified in the standards. Six port faceplates may be used on an as needed basis and upon approval from the Voice analyst or Data Analyst. The Voice cables will use the top two positions of the faceplate. Any unused slots within the faceplate will be covered with a blank insert.
- Horizontal cables will have the pairs split in the following configuration for each cable. The Blue, Green and Orange pair will be terminated on a 568B jack and positioned on the left side of the faceplate. The Brown pair will be split and terminated as the Blue pair on a 568B jack and positioned in the right slot, next to the first jack.
- Comb and dress all cable as to be appealing to the eye, both within the TR and within the cable trays and J-hook runs. Data and Voice cable are to be run separately, each in their own J-hooks, cable trays and conduits. Cross-connect wire shall also be run in a neat and eye-pleasing manner through the wire management system on the frames.
- Always leave an appropriate pull string with any cable along its main cable pathway through the building. Separation of the pull string to facilitate shorter runs must have another pull string inserted and secured to the end of the original pull string which had been cut to ensure full hallway and runway coverage.
- Deliver a minimum of four copies of clear and accurate handwritten red-line drawings to the respective voice and data owners a minimum of 3 weeks before move in date or as dictated by the respective owner.

Part 7g Fiber Optic Cabling:

- All metallic armored cable will be grounded at each end
- Before the start of the project, the project manager or IS analyst in charge of the fiber optic cable should be contacted. This is to determine the proper fiber type, closure and connectors to be used for the project.
- All fiber optic cabling will originate within the Main TR or BEF located in the facility. A separate rack will be designated as indoor fiber for distribution to the other TRs. Fiber backbone cabling to each TR will be a hybrid cable and will be plenum rated with the following typical configuration: refer to page 8 for the

guidelines for fiber strand planning quantities, unless otherwise specified. Contact the appropriate owner (WSUM, BJC, or TFC) for the specific number of fiber strands to be placed.

- All new building construction will receive 50 micron OM3 laser enhanced multimode. WUSM, BJC, or TFC will specify requirements at beginning of each installation. All connectors will be LC to LC unless otherwise requested.
- Support all fiber cabling within innerduct, plenum rated, unless armor rated fiber, for the entire length of its run. Innerduct and MIC interlocking armor fiber will be identified at 40 to 50-foot intervals with standard label (Panduit PST-FO) and on either side of any penetrations, with its trunk name assigned by the appropriate owner for the project unless housed within rigid conduit.
- Main riser paths will be supported using series 44 EZ Path through floors. Three innerduct will always be installed in any conduit carrying fiber cable. Appropriate pull strings will be left within each innerduct, end to end. Underground applications will also include a #10 wire for location purposes when PVC piping is used. The EZ Path shall terminate at the ceiling space of each floor and restart just below the ceiling deck with the innerduct exposed and secured to the wall using appropriate size D-rings.
- Branch routing for single fiber distribution from the riser may be innerduct only supported by B-Line hooks. Innerduct must be plenum rated where airspace requires.
- Install pull boxes where branching occurs, or where turns in the conduit are required. The pull boxes will be wall-mounted, with support brackets used to raise the box to allow innerduct to pass behind. The boxes will be of appropriate size to allow for 30 feet of slack to be coiled within, while maintaining the minimum bend radius rating for the cable. Standard NEMA connectors will be used to connect innerduct to the box. The cover will be removable with space left for additional fiber support.
- Always use 4 J-hooks to mount a 30 foot service loop to the wall, as high as it can be mounted so that they are up and out of the way.
- All fiber enclosures, on either end of the fiber, will be terminated in a CCH Corning closet connector housing. Within the TR, the enclosure will be installed at the top-most portion of one of the racks along with a Corning horizontal fiber management unit (optional per project manager) installed underneath the fiber enclosure box. Terminations within the Main TR will be a series of CCH enclosures terminated within the designated rack from top to bottom. The trunk name will be provided at the beginning of the project and all fibers should be clearly identified on both ends.
- All fiber termination in the corning connector housings should follow the Corning Best Practices for terminations. The link to the Corning installation guide is http://csmedia.corning.com/CableSystems//Resource_Documents/SRPs_rl/003-877-QSG.pdf

All individual strand terminations will be LC to LC unless directed otherwise by the Project Manager or Data Analyst. Multi-mode connectors will be beige or aqua and Single-mode connectors will be blue:

1. Corning Unicam, SC, MM multimode Ceramic 62.5
2. Corning Unicam, SC SM Single mode SPC
3. Corning, LC,50 Micron OM3, MM multimode
4. Corning, LC, SM, Single mode

- All 62.5 multimode fiber optic cabling will be orange, plenum rated, in innerduct or armored, Corning brand fiber unless otherwise specified by owner.
- All 50 Micron OM3 fiber will be Aqua in color, plenum rated in innerduct or armored, Corning brand fiber unless otherwise specified by owner.

- All single mode fiber optic cabling will be yellow, plenum rated, in innerduct or armored, Corning brand fiber unless otherwise specified by owner.

Part 7h Labeling: - Voice/ Data – Fiber Trunks

- Labeling must be in place at both ends of the cable, backbone or innerduct by the completion of the job.
- Identify all voice and data cabling by their major building code i.e. the TR, designated ID and the cable number. The cable location within the patch panel or on the Homaco frame determines its specific number.

Voice

- The building identifier, TR identifier and their cable number shall identify the labeling space above the voice jacks. (Example: The voice label for a cable in Barnes-Jewish Central Pavilion TR on the fourth floor, terminating on the 9th cable location of the Homaco frame would read as follows:

EXAMPLE

RJ/QT4A- 4015 A/D See Appendix E

- The first group (RJ) identifies the building that houses the wall plate.
- The second group (QT) identifies the building that houses the TR.
- The third group identifies the TR ID (4A – Fourth floor “TR”)
- The fourth group identifies the floor number (4) and cable (015) within the TR.
- The last group identifies the cable pair positions on pins 4 & 5 (A= blue, D= brown)

Data

- The TR ID and the patch panel location number will identify the labeling space below the data jacks. (Example: Two data cables for drops located in Queeny Tower on the 4th floor TR in the 32nd and 33rd patch panel locations would read as follows:

EXAMPLE

See Appendix E

4032 QT-4A 4033 Dual Data Drops
QT-4A 4031 Single Data Drops

- The first group identifies the 32nd cable on the fourth floor.
- The second group (QT) identifies the building that houses TR.
- The third group identifies the TRID (4A – 4th floor) TR.
- The last group identifies the 33rd cable on the 4th floor.

Fiber Trunks

EXAMPLE

"BIH01C-5.4A/96S/ML00A-2.7A" BJCIIH to Medical Library 96 strands of single mode fiber.

BIH= building location

01C= TR or MDF location where fiber is terminated

5.4A= rack location in this case rack #5

.4 is the fiber termination box in the rack

.4 is the box number

A is the row the fiber is terminated in the fiber box in this case row A or 1

96 means 96 strands fiber.

S is for Single Mode Fiber If it said M that would be Multimode Fiber

The owner's representative will identify fiber-labeling requirements at the start of the project. The owner's representative will also designate the appropriate TR name along with supplying the labeling scheme for the both ends of the fiber.

Patch Panel

Labeling on the data patch panels will include only the location number as shown on exhibit 5a, included with this document. The labels will be attached so that they are clearly visible and not hidden by cross connect wiring. (Labels above the jack on patch panels fed from wire management below and below the jack on patch panels fed from above wire management.)

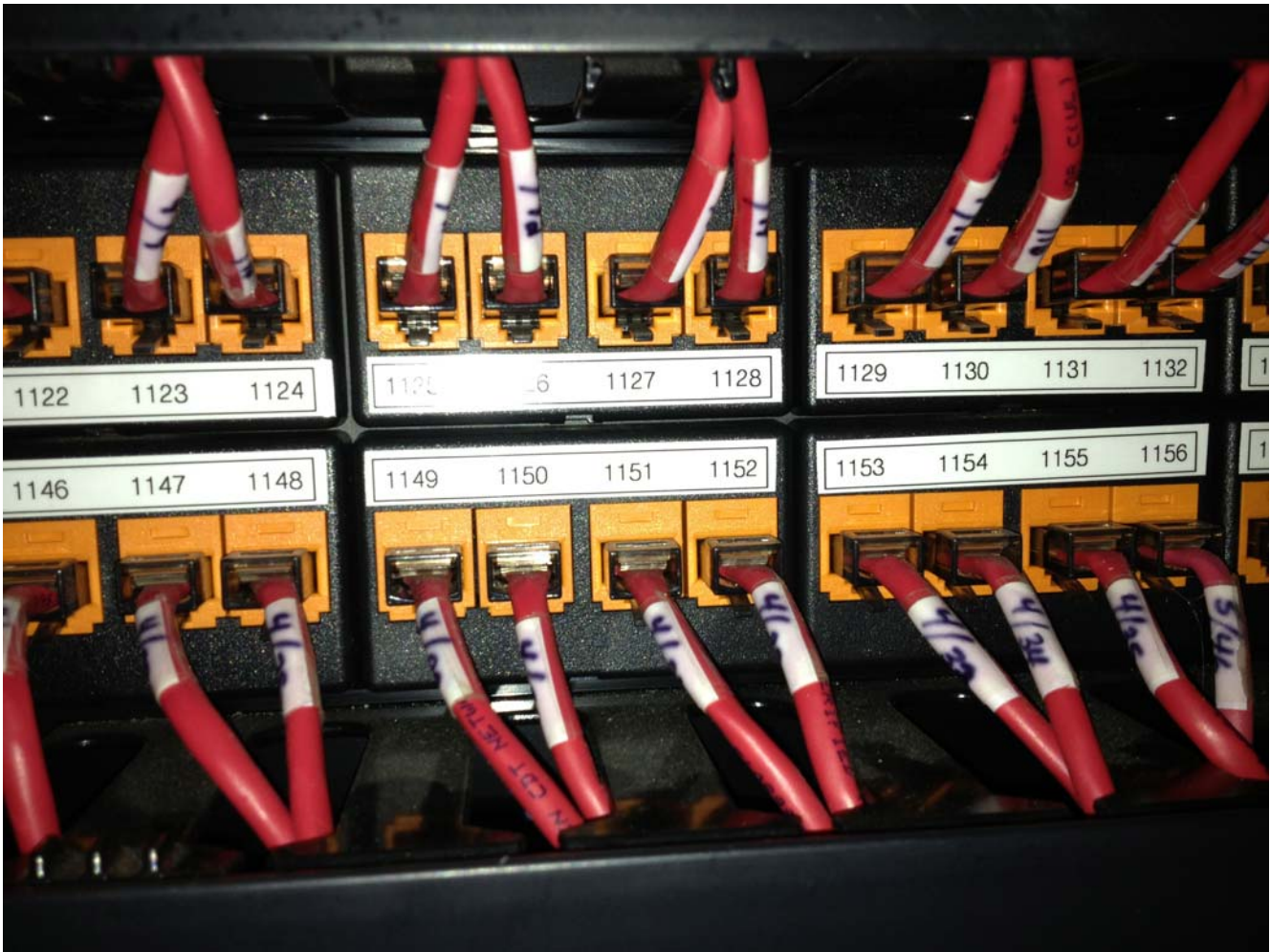

Exhibit 5a: Picture of Patch Panel (INCORRECT CABLE LABELING HAND WRITTEN)

Conduit

- Any new conduit going in, must be marked with a typed label, (not hand written) white with black type, A and Z location. Where it starts and stops. Internal and external to buildings. (i.e.: A=SRF BEF Z=CID DORM BEF) Labels need to be minimum of 1.5" wide and can be put on the conduit horizontally. Conduits going to man holes, have contractor put what manhole #, etc., label on both ends. We also want to know what cable is running within that conduit. Cable name and pair count. Splice cases will be done in the same manner conduits must be marked every 40' to 50' with identification.

Riser Cable

All copper cable 25 pair or bigger must be marked every 40' to 50' with cable identification. Tie wrap cable flags need to be used. Cable to be marked with A and Z locations also pair count. Academic campus and designated sites should be marked TFC Telecommunications Community campus and designated sites should be marked voice services.

Part 7 i Raceways and Cable Runs:

- Whenever possible, a cable tray should be installed during new construction for large cable runs. Under normal cable density conditions or existing buildings with limited ceiling space, J-Hook type cable runs are acceptable. The hooks shall be 4" cable hooks in major routes with smaller 2" cable hooks for branch routing into rooms and suites. The hooks should be no farther than 5 feet apart and installed in such a manner to allow a straight run with as few bends and transitions as possible.
- Install a pull string within the cable run and replace after every cable installation. Branch routes should also have pull strings installed when feeding large spaces such as cubicle bays, suites, etc.
- **DO NOT use tie straps within station cable runs, use velcro.**
- All clamps should be in place within the cable Hook at the completion of the cable installation.
- Install cable Hooks in pairs to provide a secondary route when cable density reaches capacity within the first hook.
- The hooks should be anchored by threaded rod minimum size to be no less than 3/8" to the ceiling deck or pan structure whenever possible. Anchoring to ribbed joist is acceptable in some applications of branch routing. Main routes should always be anchored in concrete. Wall mounted applications require pre-approval by the Owning Data Communications Analyst/Project Manager or voice Analyst managing the project. Under NO circumstances is the use of pencil rod an acceptable hanger application. J-Hooks are NOT to be supported or secured to other J-Hooks.
- Provide a documented blue print installation denoting the exact route as nearly as possible. Blueprints should also note abnormalities such as elevation changes within the run, detours to avoid obstacles such as venting and plumbing stacks, or deviation from the standard side by side configuration of hooks.
- Firewall penetrations along the main cable route shall consist of Series 44 EZ Path to be installed in pairs. Color to be determined by Project Manager.
- In existing conduits the conduits containing cable will be plugged with the appropriate fire rated putty or seal bags at completion of the job. The second conduit will require a metal bushing and 4" Steel disc inserted to maintain fire rating. The disc will be removed at the time when cable density in the first conduit reaches capacity and fire rated caulk will be utilized at that time.
- Branch route wall penetrations will be made using an appropriate size EZ Path for cables being installed.
- Fire protection regulations for the individual municipality must be met. Systems used (2hour, 3hour, 4hour, etc.) will be based on communications with owner's Facilities Engineering on wall and ceiling construction. The contractor must meet with the owner's Facilities Engineering requirements. Systems used must be UL RATED. It is the contractor's responsibility to identify the fire rating of the wall requiring the penetration. The contractor must properly fire stop the wall penetration. For all concerns contact the appropriate project coordinator.
- **When raceway is necessary to run down the wall use raceway down to the surface mounted gang junction box using a standard face plate.**
- Please see the New Cable/Raceway Installation Standards document from the BJC Design and Construction for specific requirements or WUSM Design & Construction as appropriate.

Part 7j Additional Information:

- Perform all work in such a manner to prevent Union work stoppages conflicts.
- When work requires coordination with other contracting firms, the contractor shall be responsible for scheduling and deadlines created by the project.
- All test results, fire protection and completed drawings must be provided before final payment will be issued.
- Comply with all local, state and federal laws, and these standards assigned by BJC, WUSM and TFC personnel, to govern all low voltage and electrical equipment installations.
- Coordination with occupying tenants will be performed by the contractor and all user driven requirements for infection control, hazardous materials and patient/occupant safety shall be considered at all times. Coordination with BJC Infection control must be conducted regularly and information given to BJC about where you will be working and when.
- BJC/WUSM Infection Control procedures include bleaching systems using Bleach Bottle Mixer (Mixer ML 1060, Bleach Cartridge ML 102) which can be found at www.marketlabinc.com or by calling 1.800.237.3604. For complete procedures call Loie Ruhl @ 454.5573
- Inform BJC/WUSM plant facilities engineers of all activity within BJC/WUSM buildings and adhere to additional standards imposed by those engineers.
- Additional BJC/WUSM facilities standards and requirements such as identification badges, approval of cable routes and space assignment, will be addressed on a per facility, per application basis.
- The assignment of a BJC/TFC Data Communications Work Request Form (Work-order) and its identifying DC number or a WUSM work order must precede all work. All billing will reference the DC number and whether it is partial or complete bill out. No Data Communications or Telecommunications work shall be performed without prior approval and assignment by either department or the analyst assigned to the project.

Part 7k Architectural Drawing Standards:

- Voice & Data ‘Drop Symbols’ – The following diagram identifies the standardized symbols that should be provided in architectural drawings to BJC or WUSM as appropriate to identify ‘Voice’ and ‘Data’ drops.

	1 Wireless Data POE (Power Over Ethernet)	1 Voice	1 Data	1 Voice Wall Phone	1 Voice 1 Data	1 Voice 2 Data	2 Voice 1 Data	2 Voice 2 Data	3 Voice 2 Data
Drop Symbol									
Number of Cables	1	1	1	1	2	3	2	3	3
Face plate Ports Required	See Note 4	2	1	1	3	4	3	4	6

Note 1 - Face plate ports are actual number of jacks used within a face plate. A four (4) port face plate is the norm. However, if the number of ports required exceeds four (4), then a six (6) port faceplate should be used.

Note 2 - Any requirements exceeding those above would necessitate the use of additional 'cut in' boxes.

Note 3 - Each Voice requirement assumes that the first port is wired 568B (BL,GR,OR) and the second port is wired 568B (BR). More than two voice requirements should follow single pair 568B standards.

Note 4 - Wireless access points are typically mounted above the ceiling. The Ethernet cable plugs directly into the access point. With few exceptions, no face place would be required. Ethernet cable normally provides power to the access point.

The following options are using either a 4-port or 6-port face plate and one (1) back box. All other options will require an additional back box and appropriate face plate.

1 Voice: One (1) 4-pair Voice Cable: One (1) 4-port faceplate, ivory.

- Top left port-three (3) pair (BL, GR, OR), 568B, ivory jack.
- Top right port - one (1) pair (BR), 568B, ivory jack.
- Bottom left & right ports, ivory blank insert

1 Data: One (1) 4-pair Data Cable: One (1) 4-port faceplate, ivory.

- Top right & left ports, ivory blank insert
- Bottom left port - four (4) pair (BL, GR, OR, BR), 568B, orange jack.
- Bottom right port - ivory blank insert.

1 Voice (W): One (1) Wall Phone-One (1) 4-pair Voice Cable: faceplate.

- Single port - one (1) pair (BL), 568B

1 Voice/1 Data: One (1) 4-pair Voice Cable. One (1) 4-pair Data Cable: One (1) 4-port faceplate.

- Top left port - three (3) pair (BL, GR, OR), 568B, ivory jack.
- Top right port - one (1) pair (BR), 568B, ivory jack.
- Bottom left port - four (4) pair (BL, GR, OR, BR), 568B, orange jack.
- Bottom right port - ivory blank insert.

1 Voice/2 Data: One (1) 4-pair Voice Cable/2-4-pair Data Cables: One (1) 4-port faceplate.

- Top left port - three (3) pair (BL, GR, OR), 568B Electric Ivory jack
- Top right port - one (1) pair (BR), 568B
- Bottom left port - four (4) pair (BL, GR, OR, BR), 568B Blue jack
- Bottom right port - four (4) pair (BL, GR, OR, BR), 568. Blue jack

2Voice/2 Data: Two (1) 4-pair Voice Cables/2-4-pair Data Cables: One (1) 6-port faceplate, ivory.

- Top left port - three (3) pair (BL, GR, OR) 568B Electric Ivory jack
- Top right port - three (3) pair (BL, GR, OR) 568B Electric Ivory jack
- Top middle port – one (1) pair (BR) 568B Electric Ivory jack
- Bottom left port - one (1) pair (BR) 568B Electric Ivory jack
- Bottom middle & right port - four (4) pair (BL, GR, OR, BR), 568B, blue jack.

Part 8: Wireless

Page intentionally left blank for future use

Part 9: Medical Office Building (MOB)

Page intentionally left blank for future use

Part 10: Physician's Office building (POB)

Page intentionally left blank for future use

Part 11: Clinical Office Building (COB)

Page intentionally left blank for future use

Part 12: Outside Plant

Page intentionally left blank for future use

Part 13 – Barrier & Above Ceiling Policies and Procedures

Part 13a – BJH Barrier Integrity Policy and Procedures (BIPP)

**BARNES-JEWISH HOSPITAL
Department of Facilities Engineering**

ENGINEERING SPECIFICATIONS AND MATERIALS GUIDELINES

**BARRIER INTEGRITY POLICY & PROCEDURES (BIPP)
As of March 31, 2009**

1.1. PURPOSE

- A. Many walls and all floors in healthcare facilities are required by national and local fire and life safety codes to be constructed to provide a rated fire or smoke barrier to protect patients and other occupants from fire and smoke, among other things. Due to their critical role in fire compartmentation and life-safety, these barriers are required to be built, monitored and managed to preserve life-safety, to protect property and to avoid business interruption.
- B. To provide procedures that help insure continuous integrity of barriers over time. A policy that provides clear instruction on:
 - (1) How openings in barriers shall be sealed
 - (2) Minimum qualifications required of installers
 - (3) Providing evidence of compliance
 - (4) Consequences for noncompliance
- C. The policy applies to all staff, Vendors and Contractors that penetrate barriers.
- D. WHY: To control the integrity of all constructed barriers (walls, floors and ceilings) in the environment of care over time as cabling moves, adds and changes and other construction activity and maintenance create openings for areas.

2.1 POLICY

- A. All openings in rated barriers shall be protected with UL Classified Firestop Systems, and fall into one of three groups:
 - (1) EXISTING FIRESTOPPED OPENING (EFO): These are existing openings that are firestopped *correctly*. Existing Firestopped Openings shall not be opened, disturbed, accessed, touched or have their firestop tampered with in any way, unless clearly labeled as a “High-Traffic Opening”. Once an Existing Firestopped Opening is reentered, it is now a New Firestop Opening, and responsibility for re-sealing falls on you, the installer.
 - (2) EXISTING UN-FIRESTOPPED OPENING (EUO): These are openings created by others that are either not firestopped correctly or not firestopped at all. These openings are a serious hazard, and must be corrected. It is the responsibility of ALL staff, Vendors and Contractors to look for and report Existing Un-firestopped Openings to Design & Construction Project Manager on Renovation and Construction projects to make repairs while completing the renovation/project. Contact Facilities Engineering Support Service Center at 747-7000, prompt #2 for in-house repairs and maintenance. You, the installer, will not be held accountable for Existing Un-firestopped Openings that are not yours, unless on a

renovation / construction project. When you report them; and you may be paid to correct ones that you report. IF YOU DO NOT REPORT EXISTING UN-FIRESTOPPED OPENINGS, YOU MAY BE REQUIRED TO CORRECT THEM AT YOUR OWN EXPENSE.

- (3) **NEW FIRESTOP OPENING (NFO):** These are either new openings created by you (The Installer) or existing openings accessed by you. In either case, if you touch an opening, you shall be responsible for firestopping or re-firestopping it. New Firestop Openings that protect occupied space shall be protected with UL® Classified Firestop Systems.

TYPE OF OPENING	ACTION REQUIRED	WHO PAYS TO FIRESTOP
Existing Firestopped Openings	None	N/A
Existing Un-Firestopped Openings	You Firestop D&C Project	D&C Project Manager
Existing Un-Firestopped Openings (Non-Project Related)	You Report Building Finishes	Building Finishes Supervisor Paint/Vinyl
New Firestop Openings	You Firestop	You

3.1 PERFORMANCE WORK

A. All Existing Un-firestopped Openings and New Firestop Openings in rated fire barriers shall be sealed:

(1) In accordance with the requirements of BARNES-JEWISH HOSPITAL approved UL® Classified Firestop system as published in the *SCHEDULE OF APPROVED UL® SYSTEMS* (See attached exhibit 1) (STI firestop products only)

(2) At the end of the each shift, unless there are Interim Life-Safety Measures (ILSM) is in effect for the project. It is the Contractor’s responsibility to inform BJC assigned Project Manager immediately to request information on ILSMs, follow those extraordinary measures being implemented, and to notify the organization if the work is going beyond the original scope so the ILSMs can be implemented.

(3) All Existing Un-firestopped Openings and New Firestop Openings shall be added to the *Statement of Conditions, Part 4: Plan for Improvement* (PFI) Document and documented in the hospital’s CMMS to repair. If not repaired within 30 days. It is the Contractor’s responsibility to furnish this information to Project Manager and Facilities Engineering Building Finishes Supervisor in writing.

4.1 QUALITY ASSURANCE

A. All Existing Un-firestopped Openings and New Firestop Openings shall be sealed by personnel holding a current, valid Firestop Installer’s Training (FIT) Level I or Level II certificate as issued by Specified Technologies, Inc. (800.992.1180)

B. Work that is not documented is considered incomplete and unacceptable. All firestop installers shall furnish evidence of compliance in two ways:

- (1) Each opening shall be identified with an adhesive label that provides the following information:
- (a) Installer name
 - (b) Installer FIT certification number and expiration date
 - (c) Employer (if staff, the list department/supervisor)
 - (d) Date of firestop install
 - (e) UL® System number used
 - (f) Specific location of each opening
- (2) At the end of the project, this information shall also be furnished for every opening on the attached form

(See attached exhibit 2)

5.1 ACCEPTANCE OF WORK

- A. Prior to close out of a work order and payment to Vendors and Contractors, all firestop work shall be accepted by Facilities Engineering’s Building Finishes Supervisor.
- B. Inspected work shall be rejected if:
 - (1) Installer’s certification is expired or missing
 - (2) Documentation is incomplete or missing
- C. At the Building Finishes Supervisor’s option, the work may be accepted without a visual or physical inspection, where the inspector is familiar with the installer’s work and the installer has a demonstrated level of competence and track record of compliant installations.
- D. Upon inspection of work, if 10% or more of the conditions are non-Compliant, ALL WORK WILL BE ASSUMED TO BE NON-COMPLIANT, AND SHALL BE REMEDIED.
- E. Where a visual or physical inspection is performed, inspected work shall be rejected if:
 - (1) Any Existing Un-firestopped Openings are present
 - (2) Work is non-compliant with requirements of UL® Classified Firestop Systems
 - (3) Work has a sloppy or unacceptable fit and finish
 - (4) Finished surfaces (wall and floor coverings, ceiling tiles, etc.) are damaged, soiled or otherwise compromised by you, the installer.
- F. Prior to accepting work, the Building Finishes Supervisor may perform random destructive sampling on the firestopped work.
- G. If the damaged work is accepted as compliant, the firestop shall be repaired and made complaint at the owner’s expense.
- H. If the damaged work is rejected as non-compliant, the firestop shall be repaired and made complaint at the installer’s expense.
- I. All rejected work and all work damaged by inspection shall be remedied prior to work order being closed or payment issued to the Vendor or Contractor performing the work.

6.1 LABELING BARRIERS

- A. All smoke, fire, corridor and other rated walls and floors shall be marked to clearly identify the rating of the barrier, in uppercase block letters at least 3” in height, and in a color and shade that sharply contrasts against the background surface. Ratings shall read:

LABEL	TEXT COLOR
SMOKE BARRIER	YELLOW
SMOKE WALL	YELLOW
CORRIDOR WALL	YELLOW
1 HR FIRE BARRIER	RED
2 HR FIRE BARRIER	RED

3 HR FIRE BARRIER	RED
4 HR FIRE BARRIER	RED

B. Markings shall be permanent, and may be left by stamp or stencil using roller ink, or paint only 3" lettering. Additionally, inks and paints must not pose an indoor air quality issue in occupied space.

by: C. The barrier labeling process shall be supervised and final work accepted either
 (1) Degreed professional; such as an architect or engineer or project manager.
 (2) Or by a competent individual, skilled in the trade of reading and understanding drawings of record/construction blue prints.

D. WALLS:
 (1) Walls in finished spaces shall be labeled on both sides above the ceiling grid.
 (2) Walls in unfinished spaces shall be labeled on both sides ten feet off the floor, or 18 inches below the deck above 12"
 (3) Markings shall repeat every 15 feet along the entire length of the wall.
 (4) In areas where mechanical, electrical, structural or other obstructions make it difficult or impossible to see the marking, the repeat shall increase such that a worker can immediately locate the mark upon lifting a ceiling tile or being within 4 feet off the floor above.

E. FLOORS:
 (1) All floors are fire barriers with the exception of stairwells.

7.1 CONSEQUENCES FOR NONCOMPLIANCE

- A. Staff installing or supervising the installation of firestop are bound by this policy, and those in violation of this policy will be subject to applicable BARNES-JEWISH HOSPITAL'S Human Resource Policies.
- B. Vendors and Contractors installing or supervising the installation of firestop are bound by this policy. Those individuals and the company in violation of this policy shall be dismissed from current and future work at BARNES-JEWISH HOSPITAL.
- C. Installers requiring excessive inspection time due to pattern of non-compliant work may be back charged for excessive inspection time and/or to have firestop installers with proven skills brought in to correct the work at the offending installer's expense.

FIRESTOP ACTIVITY LOG

NOTE TO INSTALLERS: All openings in rated fire barriers shall be sealed using an **approved method** (see *SCHEDULE OF APPROVED UL® SYSTEMS*) and recorded using this form. Forms must be submitted to Facilities Engineering Building Finishes Supervisor Jim Taylor upon completion of a project for all firestopped openings. Failure to comply is a violation of the Barrier Integrity policy, and will result in disciplinary action.

FIRESTOP CONDITION		
Installer Name		
Work Order #		
Employer or Department		
Date Firestopped	UL System # Used	
Location of Opening		
FIRESTOP CONDITION		
Installer Name		
Work Order #		
Employer or Department		
Date Firestopped	UL System # Used	
Location of Opening		
FIRESTOP CONDITION		
Installer Name		
Work Order #		
Employer or Department		
Date Firestopped	UL System # Used	
Location of Opening		
FIRESTOP CONDITION		
Installer Name		
Work Order #		
Employer or Department		
Date Firestopped	UL System # Used	
Location of Opening		
FIRESTOP CONDITION		
Installer Name		
Work Order #		
Employer or Department		
Date Firestopped	UL System # Used	
Location of Opening		

**BARNES-JEWISH HOSPITAL
Department of Facilities Engineering Building Finishes**

BARRIER ACCESS PERMIT REQUEST FORM

Project Name: _____ Permit Number: _____

Building: _____ Floor: _____ Near Door Tag Number: _____

Barnes-Jewish Contact: _____ Phone Number: _____

Contractor Contact: _____ Phone Number: _____

Type of Work: _____

Project Start Date: _____ Estimated End Date: _____

CMMS Assigned Work Order Number: _____

My signature confirms that I am aware of the Contractor Safety Policy and will abide by the requirement of the policy:

Print Phone Number: _____

Signature

Permit Issued By: _____ Date: _____

Penetration(s) sealed by: _____

Method/Product Used: _____

Inspection By: _____ Date: _____

SCHEDULE OF REQUIRED UL FIRESTOP SYSTEMS

NOTE TO INSTALLERS: Only The Following UL Classified Firestop Systems Shall Be Accepted In This Facility

SCHEDULE OF APPROVED FIRESTOP SYSTEMS	Sleeved	Insulated	Product(s)	Concrete Floor	Concrete Wall	GWB Wall
Bare Metallic	No	No	SSS Sealant	CAJ-1079	CAJ-1079	WL-1049
Bare Metallic	Yes	No	SSS Sealant	CAJ-1217	CAJ-1217	WL-1079
Fiberglass Insulated Pipe	Optional	Yes	SSS Sealant	CAJ-5087	CAJ-5087	WL-5014
AB/PVC Foam Insulated Pipe	No	Yes	SSS Sealant	CAJ-5133	CAJ-5133	WL-5054
Multiple Metallic	No	No	SSS Sealant			WL-1168
Multiple Metallic	Yes	No	SSS Sealant			WL-1127
Multiple Mixed	No	Optional	SSS Sealant	CAJ-8053	CAJ-8053	WL-8003
Multiple Mixed Pipe	No	No	Pillows	CAJ-8093	CAJ-8093	
Fire Retardant Poly Propylene Pipe	No	No	SSS/SSCollars	CAJ2045	CAJ2045	WL2029
Fire Retardant Poly Propylene Pipe	Optional	No	Wrap Strip Tuck In	FA2077	WJ2020	WL2048
All Plastics 1.5"-6" (Collar Device Only)	No	No	SSS/SSCollars	CAJ2125	CAJ2125	WL-2074
ELECTRICAL PENETRATIONS	Sleeved	Re-Enterable	Product(s)	Concrete Floor	Concrete Wall	GWB Wall
Single Conduit	No	No	SSS Sealant	CAJ-1079	CAJ-1079	WL-1049
Multiple Metallic	No	No	SSS Sealant			WL-1093
Multiple Metallic	No	No	SSS Sealant			WL-1168
Multiple Mixed Conduits and Tubing	No	Yes	Pillows	CAJ-8093	CAJ-8093	
Multiple Metallic	No	No	SSS Sealant	CAJ-8053	CAJ-8053	WL-8003
Flush-mounted electrical and VDV outlet boxes		No	Putty Pads			CLIV
COM/DATA PENETRATIONS	Sleeved	Re-Enterable	Product(s)	Concrete Floor	Concrete Wall	GWB Wall
Single Cable Bundle	No	Yes	Single EZ-Path	CAJ-3214	C-AJ-3214 or WJ3099	WL3219
Multiple Cable Bundles	No	Yes	Ganged EZ-Paths	F-A-3015	WJ3098	WL3218
Center hung cable tray	No	Yes	Pillows		WJ-4021	WL-4029
Open ladder cable tray	No	Yes	Pillows	CAJ-4029	CAJ-4029	WL-4008
Single Innerduct	Optional	No	SSS Sealant	CAJ-2140	CAJ-2140	WL-2093
Multiple Innerduct	Yes	Yes	Pillows		WJ-2054	WL-2178
GROUPED PENETRATIONS IN EXISTING BARRIERS		Re-Enterable	Product(s)	Concrete Floor	Concrete Wall	GWB Wall
Multiple Mixed		Yes	Pillows	CAJ-8093	CAJ-8093	
Multiple Mixed		No	SSS Sealant	CAJ-8113	CAJ-8113	
Multiple Mixed		No	SSM Mortar	CAJ-8114	CAJ-8114	
Multiple Mixed		No	SSM Mortar	CAJ-8115	CAJ-8115	
HVAC PENETRATIONS	Sleeved		Product(s)	Concrete Floor	Concrete Wall	GWB Wall
Non-Dampered Rectangular duct	No		SSS Sealant		WJ-7007	WL-7025
Non-Dampered Flat oval duct	No		SSS Sealant		WJ-7013	WL-7033
Non-Dampered Spiral duct	No		SSS Sealant		WJ-7005	WL-7026
Non-Dampered Insulated duct	No		SSS/SSW		WJ-7011	WL-7028
ARCHITECTURAL JOINTS & BLANK OPENINGS			Product(s)	Concrete Floor	Concrete Wall	GWB Wall
Walls to Flat Concrete Deck			ES Sealant		HWD-1006	HWD-0079
Walls to Flat Concrete Deck			AS Spray		HWD-1005	HWD-0044
Walls to Fluted Metal Deck			ES Sealant		HWD-0039	HWD-0034
Walls to Fluted Metal Deck			AS Spray		HWD-0086	HWD-0043
Walls to Fluted Metal Deck, Fireproofing, I-Beams			AS Spray		HWD-0140	HWD-0099
Gypsum Walls to Fluted Metal Deck, Castle Cut			ES Sealant			HWD-0153
Wall to Wall Joint			ES Sealant	WWD-0004		
Perimeter Joint, Gyp. Sheathed Stud Wall, Vision Glass			AS Spray	CWS-1002		
Perimeter Joint, Spandrel Glass, Vision Glass			AS Spray	CWS-2003		
Floor to Floor Joint			ES Sealant	FFD-1008		
Blank Openings			SSS Sealant	CAJ-0014	CAJ-0014	
Blank Openings			Pillows	CAJ-0061	CAJ-0061	WL-0010

**BARNES-JEWISH HOSPITAL
Department of Facilities Engineering**

ENGINEERING SPECIFICATIONS AND MATERIALS GUIDELINES

**PERMIT POLICY & PROCEDURES (BAP)
As of March 31, 2009**

1.1 PURPOSE

- A. To ensure the safety of our patients, visitors, and staff Barnes-Jewish Hospital must be NFPA 101 2000 edition Life Safety Code compliant and Joint Commission ready at all times for inspections of smoke walls, firewalls and floor through penetrations including installation of ceiling tiles and ceiling through penetrations (no gaps to exceed 1/8 inch). Therefore, **Barnes-Jewish Hospital** has developed and will enforce the **BARRIER ACCESS PERMIT policy and procedures**.
- B. **Approved Products:**
- (1) BJH is limiting firestop products and UL rated systems to Specified Technologies Incorporated (STI). *Only the following UL firestop systems shall be accepted in this facility.* See attached schedule.
 - (2) **STI, EZ Path** fire rated pathways must be used when remodeling or new construction projects are scheduled and/or in progress for wire and cable through penetrations. Per BJH Facilities Engineering standards and BJC Information Systems standards, EZ Paths are zero-maintenance solution for firestopping cables and wires. *EZ Paths are to be installed color coded; voice (white), data (blue), clinical (green), fire alarm (red) and miscellaneous (orange).*

2.1 POLICY

- A. **Above Ceiling and Through Penetration Training and Certification:**
All contractors and subcontractors, mechanical, electrical, plumbing and HVAC working at BJH including Information Systems, Telecommunications, Clinical Engineering, Security, Facilities Engineering and Planning, Design & Construction that construct, maintain or penetrate smoke walls, firewalls, floors and ceilings including wire and/or cable installations or removals must be trained by STI and pass the Fit Test Level I for certification. Fit Level 1 to be completed every two years. Recertification is required to ensure through penetrations are firestopped with the latest edition, correct UL rated system and installations. Training sessions will be scheduled through BJH as needed to support this requirement at no cost to staff or contractor for the training (contractor to expense the hours for their staff while attending training). STI and BJH Facilities Engineering Building Finishes Supervisor will provide training. A Test will be given at the end of certification training, which must be passed in order to receive certification. Training and testing will take four hours to complete. For the certificate training you will need to provide us with your name, address and telephone contact number. This will ensure you receive a card verifying your certification from STI. You must be capable of presenting the STI fit test certified installer card when working at BJH on through penetrations. Classes will be limited and reservations will need to be made in advance through BJH Facilities Engineering Customer Service Center @ 314-747-7000, prompt #2. If you have a current Fit Level I certificate and can prove it by presenting your card we will accept it for work at BJH. You will need to renew training on a semiannual basis.

3.1 PROCEDURE

- A. **Barrier Permits:**
- (1) No firestop is to be removed or installed at BJH without a Barrier Access Permit being approved. You must complete the Project Risk Assessment form obtained

from Infection Control Specialist Loie Ruhl at ler1631@bjc.org or phone (314-454-5573) in addition to the Barrier Access Permit.

- (2) Requests for a Barrier Access Permit should be e-mailed to BarrierAccessPermit@bjc.org or phone BJH Facilities Engineering Support Service Center at 747-7000, prompt #2. Requests will be reviewed Monday through Friday from 7:00 a.m. - 3:00 p.m. and will be approved or declined. If declined, e-mail will be sent to requester explaining reason declined and additional information required for approval. Approvals will be forwarded to the Support Service Center and requester will be e-mailed confirming approval of the Barrier Access Permit.
- (3) Approved Barrier Access Permits will be assigned a number to track the permit and the job the permit is issued on. The Barrier Access Permit will be available for pick up at the south campus BJH Facilities Engineering Customer Service Center located on the Lower Level West Pavilion.
- (4) The Barrier Access Permit must be posted (tied to ladder) when work is being performed. The Barrier Access Permit must be handed in to the BJH Facilities Engineering Customer Service Center when ready for the above ceiling punch. On projects, the construction supervisor is to hand in permits for all trades granted a permit. ***Above ceiling punch is to be completed within 24 hours Monday through Friday between 7:30 a.m. - 3:00 p.m. After turning in Barrier Access Permits the Customer Service Center will contact Building Finishes Supervisor and Lead Painters along with EH&S to perform the inspection. No Ceiling tile is to be installed before above ceiling inspection has been completed and approved by Facilities Engineering Supervisor or Lead Painters and EH&S. Building Finishes Supervisor will revisit the project after ceiling tile is installed to assure ceiling tiles are installed correctly with no gaps exceeding one eighth inch.***

4.1 FIRESTOPPING

- (1) All contractors and subcontractors working at BJH including Information Systems, Telecommunications, Clinical Engineering, Security and Planning, Design & Construction that install or remove any fire stopping, walls, floors or ceilings, must furnish the firestop information requested on the Barrier Access Permit.
- (2) All firestop must be completed and ceiling tile out for walk through on construction projects. The inspection will include all floor penetrations, wall and ceiling penetrations, ceiling top of wall, drywall and plaster condition including taping and mudding, cable trays, and support steel fireproofing. Also correct installations of UL rated systems/firestopping including EZ Path fire rated pathways installed. All new firestop and UL rated systems must meet NFPA 101 2000 Life Safety Code standards. All existing firestop deficiencies must be repaired to meet NFPA 101 2000 Life Safety Code also. Ceiling tile may be installed before inspection on wire and cable installations only, not including construction projects. Ceiling tile must be reinstalled immediately after wire or cable runs or repairs are being performed above the ceiling. Interim Life Safety measures must be implemented if ceiling tile is not reinstalled within 2-hours. *Ceiling tiles are an essential part of the smoke & fire compartments and must be installed with no gaps to exceed one eighth inch.*
- (3) Life Safety plan drawings for Smoke and Firewalls must be present at time of walk through. At completion of above ceiling punch walk through, the Barrier Access Permit will be signed and dated for approval of firestop or declined until further work is completed. No ceiling tile is to be installed until approved by Building Finishes Supervisor or Lead Painters if not present, and EH&S.
- (4) If declined, there will be another walk through that contractor must schedule to receive approval on the Barrier Access Permit before ceiling can be installed. *PD&C project managers should be present at the final inspection. Smoke and firewalls must be stenciled with minimum of 3-inch lettering, red firewall, and yellow*

smoke wall every 15 ft. and labeled with STI Smoke and Fire UL rated system used per penetration.

- (5) All documentation of firestop must be identified on a floor plan per STI UL rated firestop system and must be turned into the Project Manager upon completion of the construction project then sent to Facilities Engineering Building Finishes Supervisor at close of project.

Contractor's final invoice will not to be paid if the Barrier Access Permit has not been signed off by Facilities Engineering Building Finishes Supervisor or Lead Painters if not available, including EH&S.

Design & Construction Project Manager is to ensure Barrier Access Permit has been approved before paying final invoice. Contractors that do not adhere to BJH Barrier Access Permit policy and procedures will not be allowed to bid or work at BJH. Anyone not posting the permit will be required to **stop work** and be required to apply for a BARRIER ACCESS PERMIT.

BARNES-JEWISH HOSPITAL
Department of Facilities Engineering Building Finishes

BARRIER ACCESS PERMIT REQUEST FORM

Project Name: _____ Permit Number: _____

Building: _____ Floor: _____ Near Door Tag Number: _____

Barnes-Jewish Contact: _____ Phone Number: _____

Contractor Contact: _____ Phone Number: _____

Type of Work: _____

Project Start Date: _____ Estimated End Date: _____

CMMS Assigned Work Order Number: _____

My signature confirms that I am aware of the Contractor Safety Policy and will abide by the requirement of the policy:

Print

Phone Number: _____

Signature

Permit Issued By: _____

Date: _____

Penetration(s) sealed by: _____

Method/Product Used: _____

Inspection By: _____

Date: _____

SCHEDULE OF REQUIRED UL FIRESTOP SYSTEMS

NOTE TO INSTALLERS: Only The Following UL Classified Firestop Systems Shall Be Accepted In This Facility

SCHEDULE OF APPROVED FIRESTOP SYSTEMS	Sleeved	Insulated	Product(s)	Concrete Floor	Concrete Wall	GWB Wall
Bare Metallic	No	No	SSS Sealant	CAJ-1079	CAJ-1079	WL-1049
Bare Metallic	Yes	No	SSS Sealant	CAJ-1217	CAJ-1217	WL-1079
Fiberglass Insulated Pipe	Optional	Yes	SSS Sealant	CAJ-5087	CAJ-5087	WL-5014
AB/PVC Foam Insulated Pipe	No	Yes	SSS Sealant	CAJ-5133	CAJ-5133	WL-5054
Multiple Metallic	No	No	SSS Sealant			WL-1168
Multiple Metallic	Yes	No	SSS Sealant			WL-1127
Multiple Mixed	No	Optional	SSS Sealant	CAJ-8053	CAJ-8053	WL-8003
Multiple Mixed Pipe	No	No	Pillows	CAJ-8093	CAJ-8093	
Fire Retardant Poly Propylene Pipe	No	No	SSS/SSCollars	CAJ2045	CAJ2045	WL2029
Fire Retardant Poly Propylene Pipe	Optional	No	Wrap Strip Tuck In	FA2077	WJ2020	WL2048
All Plastics 1.5"-6" (Collar Device Only)	No	No	SSS/SSCollars	CAJ2125	CAJ2125	WL-2074
ELECTRICAL PENETRATIONS	Sleeved	Re-Enterable	Product(s)	Concrete Floor	Concrete Wall	GWB Wall
Single Conduit	No	No	SSS Sealant	CAJ-1079	CAJ-1079	WL-1049
Multiple Metallic	No	No	SSS Sealant			WL-1093
Multiple Metallic	No	No	SSS Sealant			WL-1168
Multiple Mixed Conduits and Tubing	No	Yes	Pillows	CAJ-8093	CAJ-8093	
Multiple Metallic	No	No	SSS Sealant	CAJ-8053	CAJ-8053	WL-8003
Flush-mounted electrical and VDV outlet boxes		No	Putty Pads			CLIV
COM/DATA PENETRATIONS	Sleeved	Re-Enterable	Product(s)	Concrete Floor	Concrete Wall	GWB Wall
Single Cable Bundle	No	Yes	Single EZ-Path	CAJ-3214	C-AJ-3214 or WJ3099	WL3219
Multiple Cable Bundles	No	Yes	Ganged EZ-Paths	F-A-3015	WJ3098	WL3218
Center hung cable tray	No	Yes	Pillows		WJ-4021	WL-4029
Open ladder cable tray	No	Yes	Pillows	CAJ-4029	CAJ-4029	WL-4008
Single Innerduct	Optional	No	SSS Sealant	CAJ-2140	CAJ-2140	WL-2093
Multiple Innerduct	Yes	Yes	Pillows		WJ-2054	WL-2178
GROUPED PENETRATIONS IN EXISTING BARRIERS		Re-Enterable	Product(s)	Concrete Floor	Concrete Wall	GWB Wall
Multiple Mixed		Yes	Pillows	CAJ-8093	CAJ-8093	
Multiple Mixed		No	SSS Sealant	CAJ-8113	CAJ-8113	
Multiple Mixed		No	SSM Mortar	CAJ-8114	CAJ-8114	
Multiple Mixed		No	SSM Mortar	CAJ-8115	CAJ-8115	
HVAC PENETRATIONS	Sleeved		Product(s)	Concrete Floor	Concrete Wall	GWB Wall
Non-Dampered Rectangular duct	No		SSS Sealant		WJ-7007	WL-7025
Non-Dampered Flat oval duct	No		SSS Sealant		WJ-7013	WL-7033
Non-Dampered Spiral duct	No		SSS Sealant		WJ-7005	WL-7026
Non-Dampered Insulated duct	No		SSS/SSW		WJ-7011	WL-7028
ARCHITECTURAL JOINTS & BLANK OPENINGS			Product(s)	Concrete Floor	Concrete Wall	GWB Wall
Walls to Flat Concrete Deck			ES Sealant		HWD-1006	HWD-0079
Walls to Flat Concrete Deck			AS Spray		HWD-1005	HWD-0044
Walls to Fluted Metal Deck			ES Sealant		HWD-0039	HWD-0034
Walls to Fluted Metal Deck			AS Spray		HWD-0086	HWD-0043
Walls to Fluted Metal Deck, Fireproofing, I-Beams			AS Spray		HWD-0140	HWD-0099
Gypsum Walls to Fluted Metal Deck, Castle Cut			ES Sealant			HWD-0153
Wall to Wall Joint			ES Sealant	WWD-0004		
Perimeter Joint, Gyp. Sheathed Stud Wall, Vision Glass			AS Spray	CWS-1002		
Perimeter Joint, Spandrel Glass, Vision Glass			AS Spray	CWS-2003		
Floor to Floor Joint			ES Sealant	FFD-1008		
Blank Openings			SSS Sealant	CAJ-0014	CAJ-0014	
Blank Openings			Pillows	CAJ-0061	CAJ-0061	WL-0010

CRITERIA FOR MANAGING CONTRACTOR ACCESS AND ABOVE CEILING WORK

Policy Number: 8310-
Written:

Revised:

Manager: _____

Reviewed:

POLICY

I. PURPOSE

Safety and Infection Control is paramount at St. Louis Children’s Hospital. Providing a safe physical environment has become extremely critical. Building access has become a major concern. Facility Operations is taking this move toward a documented system of access for those working within St. Louis Children’s Hospital, whether they are working on the building space, facility mechanical systems or the building itself.

Ceiling plenums and walls may be a source of dust which if inhaled by certain patient populations, could cause fungal infections resulting in severe deterioration of their health.

The purpose of this policy is to lessen the risk to patients by providing guidelines (to contractors, vendors, staff) which would result in a controlled, clean atmosphere with a minimum exposure to dust while ceilings or walls are entered for maintenance, inspection, or construction.

II. GENERAL DIRECTIVES

- A. Contractor/maintenance worker shall notify Facilities Operations a minimum of 48 hours (not including weekends and holidays) prior to the start of work requiring access to any St. Louis Children’s Hospital property. Telephone (314) 454-2700.
- B. Construction/Work permits are documents obtained through the St. Louis Children’s Hospital, Facility Operation’s Department. This permit will authorize the start of construction/work within St. Louis Children’s Hospital and any property owned by St. Louis Children’s Hospital.
- C. During normal business hours, a worker will report to Suite PL10 and fill out a “**Construction/Permission To Work Permit**” and/or an “**Above Ceiling Access Permit**” form. The permit should be obtained in advance. (**48 hours** not including the weekend and holidays)
- D. If ceiling/wall access is required for the purpose of visual inspection or equipment Operational check in "low risk areas" (see Risk Assessment Work Sheet from the Contractor Safety Policy), access can be done without an enclosure. For any other required inspections, openings that will be left unattended, an approved enclosure must be used.
- E. The contractor/maintenance worker will inform the Charge Nurse / Department Manager prior to the onset of work.

- F. The enclosure must be secured, acoustical tiles must be replaced or access panel closed **any time the worker leaves the work site.**
- G. All ceiling work should be should be planned and directed away from patient-care areas whenever possible.
- H. Patient room doors near ceiling work shall be kept closed while the work is in progress.
- I. For all work, thorough cleaning of surfaces which become exposed to dust must be accomplished by the use of a HEPA filtered vacuum or a wet mop/cloth. When an enclosure is used, it should be carefully taken down. The “**Above Ceiling Access Permit Tag**” can be removed **only after the work and cleanup is completed.**
- J. **ONLY IN THE CASE OF AN EMERGENCY: FIRE, FLOODING, ETC. CAN ACCESS TO THE CEILING BE ACCOMPLISHED WITHOUT AN ENCLOSURE. The area should be enclosed as soon as safely possible.**

III. PROCEDURE TO BE USED FOR MINOR ACCESS)

- A. "**Minor access**" is defined as visual observation, equipment check or valve adjustment in areas other than patient occupied areas. Ceilings may not be open for a period exceeding five minutes when accessing.

A PORTABLE ENCLOSURE IS **ALWAYS** REQUIRED FOR CEILING ACCESS IN PATIENT OCCUPIED AREAS.

Examples of minor access areas are as follows: administrative offices, visitor lounges, waiting areas, hallways except for those directly outside or inside the HIGH RISK AREAS.

B. Procedure:

1. Obtain an “Above Ceiling Access Permit” from Facilities Operations (PL10). **The Permit shall be in the possession of the person performing the work at all times while the work is in progress.**

The “Above Ceiling Access Tag” is to be posted next (**within 10 Feet**) to the ceiling access, attached to the ceiling, in full sight (for staff review) before proceeding with the work.

2. Inform the Charge Nurse or department manager of work in the area.
3. Keep patient room doors near ceiling access closed while work is in progress.
4. Open ceiling tile or ceiling/wall access door, being careful NOT TO GENERATE DUST.
5. The maximum amount of time a ceiling/wall can be left open is 5 minutes.
6. The ceiling/wall, while in the open condition, cannot be left unattended. Any additional openings required for inspection that are unattended must be sealed. Ceiling tiles must be replaced or access panel closed **BEFORE** worker leaves

the work site.

7. All surfaces which have been exposed to dust must be cleaned with a damp towel or vacuumed with a certified HEPA filter vacuum before leaving job site.
8. Ceiling Access Permit Tag can only be removed after the work and area cleanup is complete. All “permits and tags” will be returned to Facilities Operations Office, Suite - PL10 upon completion of work.

IV. PROCEDURE TO BE USED FOR MINOR ACCESS IN A HIGH RISK AREA AND ALL MAJOR ACCESS - This includes the BMT, Cancer Center, PICU/NICU, OR and other areas as defined in the “Construction Safety Policy, Appendix G”.

A. Procedure:

1. Obtain an “Above Ceiling Access Permit” from Facilities Operations (PL10). The permit shall be in the possession of the person performing the work at all times while the work is in progress. The “Above Ceiling Access Tag” is to be posted next to the ceiling access, attached to the ceiling, in full sight (for staff review) before proceeding with the work.
2. Patient room doors, near work, shall be closed while work is in process.
3. A **portable vinyl enclosure or a polyethylene shroud**, of fire-retardant material will be used at each and every access point. The enclosure shall be large enough to enclose all related activities and materials, i.e. ladders, tools, vacuum, wiring, etc.
4. The enclosures must remain in place until the ceiling is completely secured (all access closed and the interior access, (panels) of the enclosures closed).
5. The polyethylene shrouds/barriers must be attached to ceilings, walls, and floors with the use of tape. All edges must be tightly sealed. If necessary the seam on the ceiling will be reinforced with a frame and flat head screws. Care should be taken to minimize damage to the finished surfaces. The enclosure will have a 3-foot overlap of plastic or zipper type entrance to decrease the risk of any airborne dust escaping the enclosure.
6. If the worker needs to crawl about pipes, ducts, or other building infrastructure to investigate a condition, the worker must put on a mask, disposable white coveralls and disposable shoe covers before going above the ceiling. Afterwards, the worker must remove the coveralls carefully, turn the coveralls inside out and deposit the coveralls into a plastic trash bag. The bag shall be discarded outside the patient area.
7. When a worker leaves the work site, the ceiling access must be completely closed or protected by an appropriate barrier.
8. Thorough cleaning of surfaces which become exposed to dust must be accomplished before leaving the job site. The cleaning can be done by the use of either a HEPA filtered vacuum or damp rag.
9. Ceiling Access Permit Tag can only be removed after the work and area cleanup is

complete. All "permits and tags" will be returned to Facilities Management Office, Suite – PL-10 upon completion of work.

B. Equipment:

Prefabricated Portable Enclosure: (see **A: Procedure**)

1. Size: 5 feet by 3 feet (approximate size)
2. Frame: Heavy duty adjustable
3. Enclosure: vinyl or polyethylene - fire-retardant

C. Protective Clothing:

1. Coveralls - Disposable - Tyvek Safety Suit
2. Shoe Covers - Disposable - Tyvek Shoe Covers
3. Mask

V. Enforcement:

General:

1. Periodic rounds will be made by Hospital Building Management.
2. All Hospital Staff are "empowered" to report violations.
3. In cases of violation, Contractor/Building Department information will be extracted from the "Above Ceiling Access Permit" and/or "Ceiling Access Tag".
4. A record of all ceiling/wall access violations will be maintained by Facility Operations.
5. Violations may affect status as a responsible contractor for future bidding of work.

Contractor:

1. Contractors and Vendors, violations may affect status, as a responsible contractor, for future bidding of work.
2. A breach of this policy may result in the Hospital terminating the Contractor or Vendor's contract and/or cause the Contractor or Vendor to be barred from bidding on future work at St. Louis Children's Hospital.

SLCH Facility Operations Staff:

All craft personnel will sign the attached signature sheet indicating acknowledgment that they have read and understand the procedure.

Acceptance:

Date: _____

Facility Services _____

Infection Control _____

Environmental Health and Safety _____

Missouri Baptist Medical Center is following the direction of NFPA, CMS, and The Joint Commission for the Accreditation of Hospital Organization (TJC) to maintain the rating of fire and smoke partitions and to properly support wires in and above ceiling spaces. Penetrations and improperly supported wires are the result of utilities such as conduit, pipe, duct work, communication lines, phone lines, and television lines being installed without being properly supported, and the penetrations in walls not being properly sealed.

In order to better manage these penetrations, effective immediately MBMC will be utilizing both an Above Ceiling work permit and a Fire/Smoke Barrier penetration permit (attached). Each permit will also be available through the Facilities office at the time work is being completed.

When it is necessary to remove ceiling tiles to troubleshoot or make repairs, Form A will be issued by the Facilities office and must be displayed at all times while work is being performed. A signature will be required both before and after work is completed. If a penetration through a smoke or firewall is necessary, Form B needs to be filled out and the penetration must be firestopped and signed off by a member of the Facilities team before the ceiling tile is replaced. The invoice will not be processed until a member of Facilities has signed off on the form.

Please contact me if you have any questions regarding this new process.

Sincerely,

Bill Mellett
Manager, Facility Services
Missouri Baptist Medical Center
[314 996-5162](tel:3149965162)
[314 713-6762](tel:3147136762) cell
[314 996-5473](tel:3149965473) fax
wpm7954@bjc.org

A	MBMC FACILITIES SERVICES STANDARD PRACTICE
"Construction/Above Ceiling Work Permit" Missouri Baptist Medical Center	<i>Permit Number:</i> _____

Location of Work: _____ Contractor: _____
 MBMC Project Manager: _____ Phone: _____

I. GENERAL

Missouri Baptist Medical Center is following the direction of NFPA, CMS and The Joint Commission for the Accreditation of Hospital Organization (TJC) to maintain the rating of fire and smoke partitions and to properly support wires in and above ceiling spaces. Penetrations and improperly supported wires are the result of utilities such as conduit, pipe, duct work, communication lines, phone lines, and television lines being installed without being properly supported, and the penetrations in walls not being properly sealed.

II. PROCEDURE

1. This **Permit to Work** is required for any above ceiling work performed by contractors on the MBMC Campus and must be secured **prior** to beginning the project. The permit must be obtained from the Facilities Office on the ground floor of the Main Tower, (314) 996-5162.

2. The person performing the work must notify the appropriate Facility Services contact at the following stages of work:

a. Prior to the commencement of work

- i) Work may not proceed until the persons desiring or performing the work and the appropriate Facility Services person is contacted and inspections are complete.
- ii) **Any pre-existing conditions should be noted on the Permit otherwise it will be understood that the contractor or system department is responsible for repair of these conditions.**

b. Before any work is concealed

- i) Any damage to the ceiling or other structure is the responsibility of the contractor or system department performing the work and shall be repaired before work is approved.

c. After the work is completed.

3. All penetrations and attachments must be made in accordance with the UL Fire Resistance Directory and using approved Hilti Product. These resources are available for reference in the Facilities Office, 314-996-5162.

4. Supporting work from the ceiling grid, ceiling grid wire or fire control piping is prohibited.

5. The costs of any repairs not 100% complete upon inspection, shall be invoiced to contractor or system department indicated on the Above Ceiling Work Permit.

The **person of contact** for this process at Missouri Baptist Medical Center is:

Primary: William Mellett, Manager of Facility Services 314-996-5412
Secondary: Geoff Link, Manager of Facility Services 314-996-5334

Prepared By: William Mellett <small>C:\Users\w1822\AppData\Local\Temp\50f9pwwic_\Form_A_Above Ceiling Work Permit_1.doc</small>	Page 1 of 2	Date Of Issue: 5-30-14
---	-------------	------------------------



MBMC FACILITIES SERVICES STANDARD PRACTICE

**"Construction/Above Ceiling Work Permit"
Missouri Baptist Medical Center**

Permit Number:

Missouri Baptist Medical Center – CONSTRUCTION - ABOVE CEILING, WORK PERMIT

Name _____ Date _____

Department / Company _____

Account Number _____ Cost Center _____

Phone _____ Fax _____

Location Of Work _____

Facility Services Provided **Infection Control** a **copy** of Risk Assessment - Date _____

Description of Work

Wiring to be installed or modified:

Communication _____ Door Control _____ Electric low or high voltage _____ Fiber Optic _____
Fire Alarm _____ HVAC _____ Security _____ Telephone _____
Television _____ Plumbing _____ Other _____

How will work be supported?

Deck _____ Existing casework _____
Existing pipe or conduit rack _____ New pipe or conduit rack _____
Existing cable tray _____ New cable tray _____
Wall _____ Other _____

Will Fire Proofing repair be required? YES _____ NO _____
Will any penetration be made in walls, roof, floor or ceiling? YES _____ NO _____
Will penetrations be made to a FIRE RATED wall or floor assembly? YES _____ NO _____

(If YES complete the "Fire / Smoke Barrier Penetration Permit")

Describe:

Will any permanent modifications be made to the visible ceiling or walls? Yes _____ No _____

Describe:

Start Date _____ Completion Date _____

Authorized to proceed _____ Date _____

Final Inspection _____ Date _____

Contractor/System Department Signature: _____ **Date:** _____

Facility Services Signature: _____ **Date:** _____

Prepared By: William Mellett <small>C:\Users\w1822\AppData\Local\Temp\XP\grpwisr__Form_A_Above Ceiling Work Permit_1.doc</small>	Page 2 of 2	Date Of Issue: 5-30-14
---	-------------	------------------------

B

Missouri Baptist Medical Center FIRE/SMOKE BARRIER “PERMISSION TO PENETRATE PERMIT”

This **PERMIT** is **required** for any penetration through designated fire/smoke separation wall/decking. This includes cabling, piping, ductwork, wiring, or any type of opening through a fire/smoke wall or decking.
This PERMIT is to be on the work site and in the possession of the staff performing work.

DATE:	TIME:	a.m.	p.m.	PERMIT #:		
STEP #1: (REQUESTOR COMPLETES)			PRE-WORK CHECKLIST - (REQUESTOR)			
Company Name:			<input type="checkbox"/> 1. Ensure smoke detectors are disabled/covered if work may produce dust. <input type="checkbox"/> 2. Notify Area Manager of work being performed. <input type="checkbox"/> 3. Verify existing penetrations can't be used. <input type="checkbox"/> 4. Post Above Ceiling Permit Tag..			
Requestor Name:						
Building	Floor	Location(s)				
		1.				
Penetration Type:			POST-WORK CHECKLIST – (REQUESTOR)			
		2.				
		3.				
		4.				
		5.				
Project/Work Order #:			<input type="checkbox"/> 1. Penetration(s) properly sealed? <input type="checkbox"/> 2. Label(s) affixed adjacent to work?			
Purchase Order #:						
STEP #2: (FACILITY OPERATIONS COMPLETES)						
<input type="checkbox"/> Verify Information from Step #1			<input type="checkbox"/> 3. Worksite cleaned up? <input type="checkbox"/> 4. Ceiling tiles replaced? <input type="checkbox"/> 5. Area Manager notified of work completion. <input type="checkbox"/> 6. Submit copy to Facility Operations for FINAL inspection and approval.			
<input type="checkbox"/> Identify UL Listing with Requestor (Listing) _____ _____ _____						
STEP #3: PERMIT APPROVAL						
Requestor Signature:					COMMENTS:	
Facility Operations Signature:						
STEP #4						
<input type="checkbox"/> Facility Operations Provides Requestor copy of Permit <input type="checkbox"/> Facility Operations Provides Infection Control copy of Risk Assessment <input type="checkbox"/> Facility Operations retains copy of Permit			FINAL INSPECTION DATE: _____ Requestor Signature: _____ Facility Operations Signature: _____			

THIS FORM MUST BE RETURNED TO FACILITY OPERATIONS BEFORE INVOICE WILL BE PAID.

Appendix E: Wall Plate Labeling Diagram

NOTE:
 *This identifier is to signify the location of the IDF where the cable is terminated in. IF, the workstation outlet resides in one building but the cable terminates in a different building use the following example. Cable is in a room in Rand Johnson but terminates in the Queeny Tower IDF, RJ-QT4A-4015A

f:\tcomdata\bjc cable standards\jack label_4.vsd
 f:\tcomdata\bjc cable standards\jack label_4.pdf
 JSG/TEB Revised 07/15/2004
 Page 1

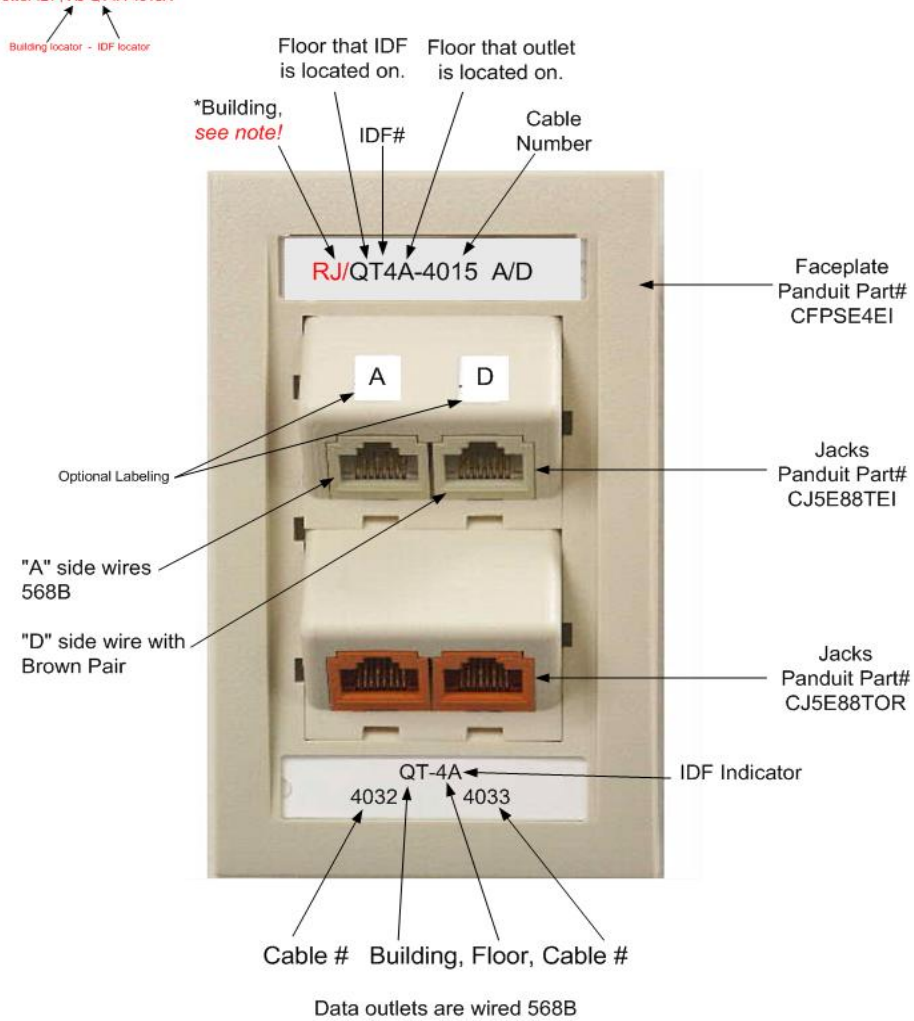

Appendix F: CAT5e Conduit Fill Ratio Guide⁶

Conduit Size	Number of CAT5e Cables	Fill Ratio	Comments
1/2"	1	40%	
1/2"	6	Experiment	
3/4"	5	40%	
3/4"	11	Experiment	
1"	8	40%	
1"	15	Experiment	
2"	26	40%	
2"	60	Experiment	
4"	52	40%	
4"	128	Experiment	

Appendix G: CAT6 Conduit Fill Ratio Guide⁷

Conduit Size	Number of CAT6 Cables	Fill Ratio	Comments
1/2"	0	40%	Not suitable for our 2 CAT6, 1 CAT5e solution
1/2"	2	Experiment	Not suitable for our 2 CAT6, 1 CAT5e solution
3/4"	2	40%	
3/4"	4	Experiment	
1"	3	40%	
1"	7	Experiment	
2"	14	40%	
2"	25	Experiment	
4"	40	40%	
4"	80	Experiment	

Appendix H: CAT5e/6 Cable Tray Fill Capacity

Cable Tray Depth	Cable Tray Width	Number of UTP Cables (CAT 6)	Fill Ratio	Comments
2"	12"	260	60%	Minimum Size
2"	18"	400	60%	
2"	24"	540	60%	
4"	12"	500	60%	
4"	18"	750	60%	
4"	24"	1000	60%	

CAT 6A At an OD of .295, you can put 50 Belden 6A cables in a 4" conduit
EZ Path Guidelines for fill ratio

⁶ Based on in-house experiment using a 24" length of 3/4", 1", 2", and 4" conduit with Belden 1785A CAT5e UTP

⁷ Based on in-house experiment using a 24" length of 3/4", 1", 2", and 4" conduit with Belden xxxxA CAT6 UTP

PATHWAY CAPACITIES

Select cable size from the Cable Diameter columns on the left to determine the maximum capacity of pathways.

Cable Diameter		Pathway Cable Capacity			
mm	inches	EZD22	EZD33	EZD44	EZD44+
3	0.118	70	368	806	868
3.5	0.138	54	266	594	648
4	0.157	35	204	437	483
4.5	0.177	28	165	357	399
5	0.197	24	130	285	323
5.5	0.216	20	108	238	255
6	0.236	15	88	195	210
6.5	0.256	12	70	168	182
7	0.275	12	63	143	156
8	0.314	6	48	99	110
9	0.354	6	35	80	90
12.5	0.491	2	20	42	42
15	0.590	2	12	30	30
18	0.708	1	6	20	20
20	0.786	1	6	12	16
25	0.983	0	4	9	9
30	1.179	0	2	6	6
35	1.376	0	2	4	4

IMPORTANT NOTICE: The above information is theoretical and is provided for estimation purposes only. Cable types, shapes, and diameters may vary and influence these calculations. Therefore, THE ACCURACY OF THIS INFORMATION CANNOT BE GUARANTEED.

Appendix I: WUSM/TFC/BJC BEF/ MAINTR/ TR Power Requirements

- The appropriate WUSM/TFC/BJC Project Manager will determine how many of each and the exact location of the power outlets at the beginning of each project.

The intent of this section is to provide a general set of guidelines for the installation of power in WUSM/BJC/TFC communication spaces. The exact number and type of power receptacles will be determined at the onset of any project. Communicating these requirements to the contractor will be the responsibility of the assigned WUSM/BJC/TFC project manager/analyst.

Power Conduit Installation Best Practices:

- All new conduit runs to racks will utilize a minimum size of 1” inside diameter to allow for future growth. Except existing areas where it is not reusable, consult with the appropriate Project Manager.
- Conduit will be routed down the outside of the closest vertical cable manager to the wall. At the base of this cable manager the conduit will be terminated into a junction box, which will be located inside the back of the cable management.
- Drilling through the cable managers to route conduits will not be permitted.
- Receptacles will be routed out of the top of the junction box and mount to the inside of the cable manager at the lowest available height. For multiple receptacle installations receptacle boxes will first be mounted side by side and if more space is required, stacked vertically. Conduits connecting junction boxes to the receptacle boxes will also be a minimum of 1” ID.
- Conduit extending to more than one rack will be routed along the base of the racks with junction boxes located in the back of each vertical cable manager passed through. As conduit passes between racks minimum height will be maintained in order to conserve usable rack space. i.e. Placed next to each other instead of being stacked on top of one another.
- Conduit or grounding and bonding will not pass through cable ladder rack (cable runway). If it is necessary to route conduit using the cable ladder rack as a path, it will be attached to the underside of the cable ladder rack and drop down the outside of the first available cable manager.
- Conduit will not run vertically inside a cable manager. An exception to this will be conduit connecting the receptacle boxes to the junction boxes at the base of the racks.
- All receptacles installed that utilize emergency power will be clearly marked with red. The preferred method is the utilization of red solid colored outlets for straight blade type receptacles and red rings on twist lock type receptacles.
- All receptacles will be clearly labeled with corresponding electrical panel and circuit designations. The accepted method is an adhesive backed printed label. No hand written labels will be allowed.
- Normal and emergency power conductors will never be placed in the same conduit.
- All electrical installations will utilize Electrical Metallic Tubing (EMT) conduit. No flexible conduit allowed.
- All communications circuits will utilize dedicated breakers. Circuits will not be shared with any receptacles located outside of the communications racks.
- Electrical boxes will be a Combination, in the base of the 10” Vertical Wire Manager, use an 8 X 8 X 4 “ metallic junction box to support 1” ID conduit knockout holes for future growth.

Appendix J - Elevator Voice Cable Design

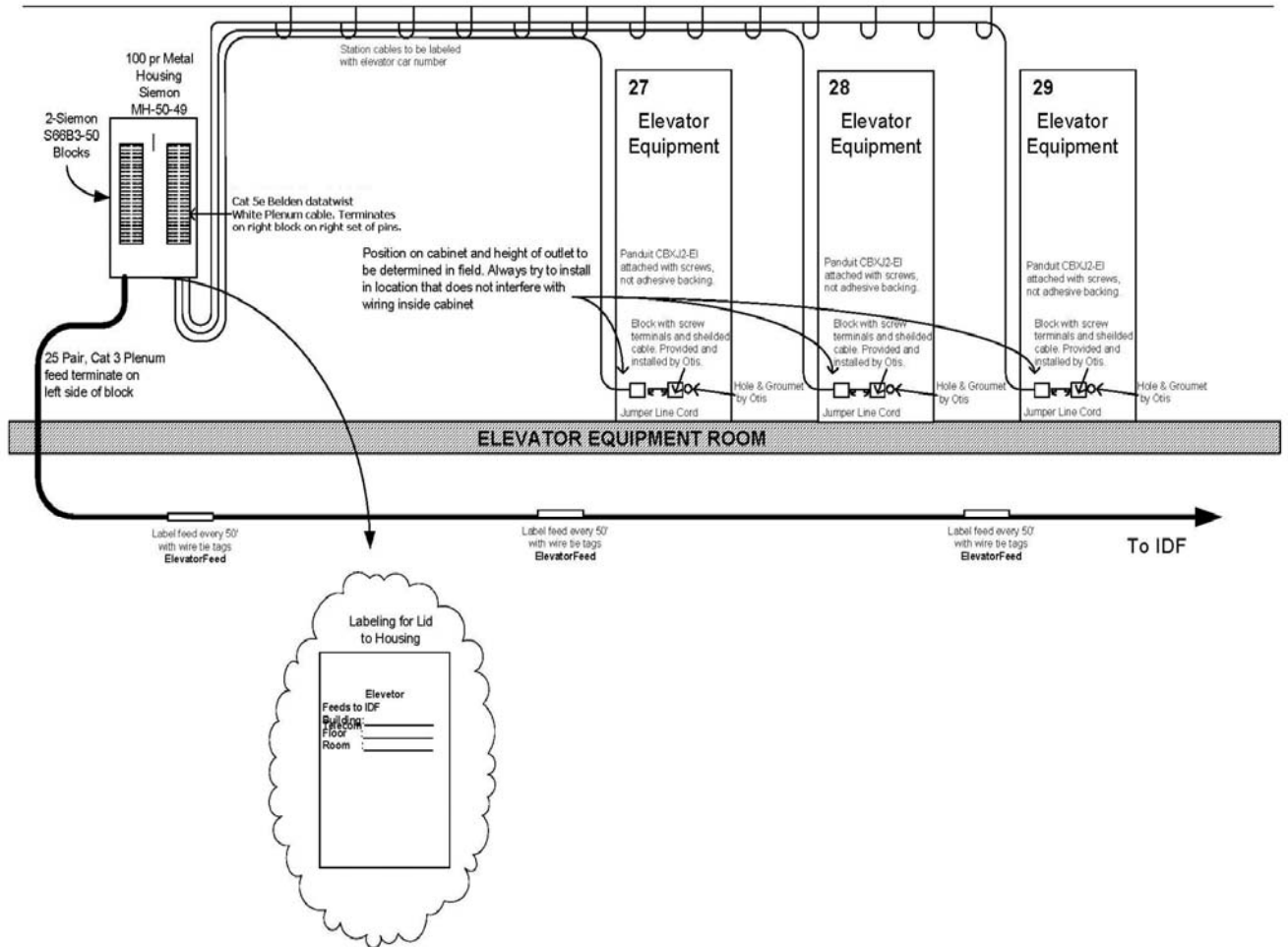

Appendix K – Paging For Academic Sites

Paging

Cabling:

- The preferred method of cabling would be an individual cable to each speaker (Home Run). If the preferred cabling method is not used then the speakers should be cabled in a Series by paging zone. Horizontal paging speaker cable will be Belden CAT 6, Neon Pink in color. The cable(s) should terminate on a 66 block located in the serving TR by the paging equipment. The paging equipment should be a Valcom series 2000 one-way page control. The size and type of the page control is determined per project. The speakers should be Valcom one-way amplified speakers. The speaker type and quantity will be determined per project.

Labeling:

- **Local Overhead Paging**

- HOME RUN CABLING:

Identify all speaker cabling by the major building code i.e., the TR, designated ID, type of paging, zone # and the cable number. The cable used for the Local Overhead Paging should be labeled as building-TR # - LOP- zone#-cable # (example CP-4A-LOP-Z1- 1). The first group (CP) identifies the building that houses the TR. The second group identifies the TR ID that houses the wiring block (4A – Fourth floor “TR”). The third group identified the type of paging Local Overhead Paging

(LOP). The fourth group identifies the zone # (Z1). The last group identifies the cable number (1-2-3-etc.). The cable(s) should be machine labeled on both ends.

- SERIES CABLING:

If cabling of the speakers is done in a SERIES method by paging zones the following should apply:

Identify all speaker cabling by the major building code i.e., the TR, designated ID, type of paging, zone # and the speaker number in the series. The cable used for the Local Overhead Paging should be labeled as building-TR # - LOP- zone #-speaker # (example CP-4A-LOP-Z1- 1). The first group (CP) identifies the building that houses the TR. The second group identifies the TR ID that houses the wiring block (4A – Fourth floor “TR”). The third group identifies the type of paging Local Overhead Paging (LOP). The fourth group identifies the zone # (Z1). The last group identifies the speaker number in the series (1-2-3-etc.). The cable(s) should be machine labeled on both ends and/or at each speaker.

- **Central Overhead Paging**

- HOME RUN CABLING:

Identify all speaker cabling by the major building code i.e. the TR, designated ID and the cable number. The cable(s) used for the Central Overhead Paging should be labeled as building-TR #- COP-cable # (example CP-4A-COP 1, etc.). The first group (CP) identifies the building that houses the TR. The second group identifies the TR ID (4A – Fourth floor “TR”). The third group identifies the type of paging Central Overhead Paging (COP). The last group identifies the speaker number (1-2-3-etc.). The cable(s) should be machine labeled on both ends and/or at each speaker.

- SERIES CABLING:

Identify all speaker cabling by the major building code i.e., the TR, designated ID, type of paging and the speaker number in the series. The building identifier, TR identifier, type of paging and the cable number shall identify all Central Overhead Paging speakers. Each Central Overhead Paging speaker should be labeled with the building-TR #- COP-speaker # (example CP-4A-COP-1). The first group (CP) identifies the building that houses the TR. The second group identifies the TR ID (4A – Fourth floor “TR”). The third group identified the type of paging Central Overhead Paging (COP). The last group identifies the speaker number (1-2-3-etc.). The cable(s) should be machine labeled on both ends and/or at each speaker.

- **SPEAKERS**

- HOME RUN CABLING:

When the preferred cabling method is used (Home Run) the building identifier, TR identifier, type of paging, zone # and the cable number shall identify all Local Overhead Paging Speakers. Each Local Overhead Paging Speaker should be machine labeled with the building-TR #- LOP- zone #- cable # (example CP-4A-LOP-Z1-1). The first group (CP) identifies the building that houses the TR. The second group identifies the TR ID that houses the wiring block (4A – Fourth floor “TR”). The third group identified the type of paging Local Overhead Paging (LOP). The fourth group identifies the zone # (Z1). The last group identifies the cable number (1-2-3-etc.). Each speaker should have a visible machine made label.

- SERIES CABLING:

When the SERIES cabling method is used the building identifier, TR identifier, type of paging, zone # and the cable number shall identify all Local Overhead Paging speakers. Each Local Overhead Paging speaker should be machine labeled with the building-TR #- LOP- zone #- speaker # (example CP-4A-LOP-Z1-1). The first group (CP) identifies the building that houses the TR. The second group identifies the TR ID that houses the wiring block (4A – Fourth floor “TR”). The third group identified the type of

paging Local Overhead Paging (LOP). The fourth group identifies the zone # (Z1). The last group identifies the speaker number in the series (1-2-3-etc.). Each speaker should have a visible machine made label.

Appendix L: Contractor Standards / Code of Conduct

On BJC/BJH/SLCH PD&C Projects the contractors are to adhere to the PD&C Blue Book document for compliance to the Safety and code of ethics.

1) General Regulations

Conduct: All contractors and their employees will refrain from any actions that are unlawful, discourteous or offensive. They will refrain from profane or insulting language. No employee shall threaten or use force or violence to restrain, coerce or intimidate any co-worker, student, employee, visitor or member of the public.

Courtesy: All contractors and their employees are expected to be polite and courteous to all persons present in or outside any of the campus buildings.

Fraternization: All contractors and their employees are under no circumstances allowed to fraternize with University/Hospital students or employees.

Smoking: All smoking and other use of tobacco products are strictly prohibited within the campus buildings and on University/Hospital property.

Drugs and Alcohol: The unlawful manufacture, sale, distribution, dispensation, possession or use of controlled substances or alcohol is strictly prohibited.

Food and Drink: Food and drink is prohibited in TR's, Computer rooms, Labs, and Procedure rooms.

Graffiti: Writing on TR walls is prohibited whether painted or not. This includes, but is not limited to phone numbers, comments, pictures, math equations, jokes, and poetry.

Appearance: All contractors and their employees are to be dressed appropriately for the work they are performing. Clothing is to be clean, and in good repair. Anyone deemed not so will **not** be granted access to Campus buildings.

Confidentiality: Contractors and their Representatives shall protect and maintain confidentiality of the work and services they provide. All communications and information obtained in the course of seeking or performing work, should be considered confidential. No confidential information should ever be disclosed without express authorization in writing.

Gifts: No Contractor or their Representative shall offer, give, or promise to offer or give, directly or indirectly, any money, gift or gratuity to any Washington University School of Medicine employee at any time. This includes, but is not limited to meals and entertainment (sporting event/show tickets). Vendors must promptly report any inappropriate solicitation from a Washington University School of Medicine employee. Vendors are required to fully cooperate in any investigation of a possible violation.

2) Work done in/on or around Campus Buildings

Burning, Brazing, Soldering, And Cutting: Any work to be done with an open flame or electric arch must be brought to the attention of the project manager, building supervisor or maintenance person in charge.

Drilling and Cutting: It is the contractor's responsibility to check the location of a proposed penetration in walls, floors, or ceilings with a visual inspection for existing electric lines, plumbing/sprinkler lines, fiber optic and/or communications cables or any other obstruction.

Damages to Campus Property or Equipment: Contractor is responsible for any damages caused by their work. All work remedies due to contractor damages will result in back charges to the contractor. This includes, but is not limited to, hand prints on walls/ceiling tiles, scuffs on walls from moving equipment and pulling cables, and overspray from painting on the equipment and/or cable support structures .

Fire Alarm Devices: Contractors must be aware of fire alarm device locations. It is the responsibility of the contractor to coordinate covering and protecting of such devices with the maintenance staff.

Dust Protections: All contractors must insure that there is no dust or tracking of dust from their work area into other areas of the campus buildings. In the event that dust will be generated, the contractor must provide appropriate protection to prevent the spread into other areas. A HEPA vacuum must be used when any drilling is to be performed in TR's, Computer rooms, Labs, or Procedure rooms.

Excessive Noise: If excessive noise due to drilling, hammering, cable pulling, etc. will be generated, the contractor should confirm with the project manager what hours the work can be performed.

Trash Removal: The contractor is responsible for the removal of all trash they generate on a daily basis. The small trash bins in TR's are there for routine maintenance (patch cable bags, UTP cross connect scraps, etc.), not contractor projects. They should not be used for fiber or copper trunk scraps, termination consumables, etc. TR floors will be swept broom clean and left free of any drywall dust, sawdust, fire stop, metal shavings, UTP clippings, etc.

The Contractor is responsible for his/her employees and any breach of these conditions can and will result in the removal of that person from the premises. The contractor will be held responsible for their employees and their actions could result in termination of the agreed upon contract.

Appendix M Copper Field Test Requirements

Category 5E and Category 6 Installations:

A. General Requirements:

1. Every cabling link in the installation shall be tested for:
 - a. Wire Map
 - b. Length
 - c. Insertion Loss
 - d. NEXT Loss
 - e. PS NEXT Loss
 - f. ACR-F Loss
 - g. PS ACR-F Loss
 - h. Return Loss
 - i. Propagation Delay
 - j. Delay Skew

In accordance with the field test specifications defined in ANSI/TIA-568-C.2 “*Commercial Balanced Twisted-Pair Telecommunications Cabling and Components Standard*”. This document will be referred to as the “Cabling Test Standard.”

2. The installed twisted-pair horizontal links shall be tested from the IDF in the telecommunications room to the telecommunication wall outlet in the work area for compliance with the “*Permanent Link*” performance specification as defined in the Cabling Test Standard.
3. One hundred percent of the installed cabling links must pass the requirements of the Cabling Test Standard mentioned in A.1 above and as further detailed in Section B. Any failing link must be diagnosed and corrected. The corrective action shall be followed with a new test to prove that the corrected link meets the performance requirements. The final and passing result of the tests for all links shall be provided in the test results documentation in accordance with Section C below.
4. Trained technicians who have successfully attended an appropriate training program and have obtained a certificate as proof thereof shall execute the tests. Appropriate training programs include but are not limited to installation certification programs provided by BICSI or the ACP (Association of Cabling Professionals).
5. The test equipment (tester) shall comply with the accuracy requirements for level III field testers as defined in ANSI/TIA-1152. The tester including the appropriate interface adapter must meet the specified accuracy requirements. The accuracy requirements for the permanent link test configuration (baseline accuracy *plus* adapter contribution) are specified in Table 3 of ANSI/TIA-1152 (Table 3 in this TIA document also specifies the accuracy requirements for the Channel configuration).
6. The RJ45 test plug shall fall within the values specified in ANSI/TIA-568-C Annex C for NEXT, FEXT and Return Loss.
7. The tester shall be within the calibration period recommended by the vendor in order to achieve the vendor-specified measurement accuracy.
8. The tester interface adapters must be of high quality and the cable shall not show any twisting or kinking resulting from coiling and storing of the tester interface adapters. In order to deliver optimum accuracy, preference is given to a permanent link interface adapter for the tester that can be calibrated to extend the reference plane of the Return Loss measurement to the permanent link interface. The contractor shall provide proof that the interface has been calibrated within the period recommended by the vendor. To ensure that normal handling on the job does not cause measurable Return Loss change, the adapter cord cable shall not be of twisted-pair construction.
9. The Pass or Fail condition for the link-under-test is determined by the results of the required individual tests (detailed in Section 4.2.2 of ANSI/TIA-1152). Any Fail or Fail* result yields a Fail for the link-under-test. In order to achieve an overall Pass condition, the results for each individual test parameter must Pass or Pass*.
10. A Pass or Fail result for each parameter is determined by comparing the measured values with the specified test limits for that parameter. The test result of a parameter shall be marked with an asterisk (*) when the result is closer to the test limit than the accuracy of the field tester. The field tester manufacturer must provide documentation as an aid to interpret results marked with asterisks. To which extent '*' results shall determine

approval or disapproval of the element under test shall be defined in the relevant detail specification, or agreed on as a part of a contractual specification.

Optional Requirements:

11. A representative from WUSM/BJC/TFC shall be invited to witness field testing. The representative shall be notified of the start date of the testing phase five business days before testing commences.
12. A WUSM/BJC/TFC representative has the option of selecting a random sample of 5% of the installed links. The representative (or his authorized delegate) shall test these randomly selected links and the results are to be stored in accordance with the prescriptions in Section I.C. The results obtained shall be compared to the data provided by the installation contractor. If more than 2% of the sample results differ in terms of the pass/fail determination, the installation contractor under supervision of the WUSM/BJC/TFC representative shall repeat 100% testing and the cost shall be borne by the installation contractor.

B. Performance Test Parameters

The test parameters are defined in the Cabling Test Standard. The test of each link shall contain all of the following parameters as detailed below. In order to pass the test, all measurements (at each frequency in the range from 1 MHz through 250 MHz) must meet or exceed the limit value determined in the above-mentioned standard.

1. **Wire Map**
Shall report Pass if the wiring of each wire-pair from end to end is determined to be correct. The Wire Map results shall include the continuity of the shield connection if present.
2. **Length**
The field tester shall be capable of measuring length of all pairs of a basic link or channel based on the propagation delay measurement and the average value for NVP. The physical length of the link shall be calculated using the pair with the shortest electrical delay. This length figure shall be reported and shall be used for making the Pass/Fail decision. The Pass/Fail criteria are based on the maximum length allowed for the Permanent Link configuration (90 meters – 295 feet) plus 10% to allow for the variation and uncertainty of NVP.
3. **Insertion Loss (Attenuation)**
Insertion Loss is a measure of signal loss in the permanent link or channel. The term “Attenuation” has been used to designate “Insertion Loss.” Insertion Loss shall be tested from 1 MHz through 250 MHz in maximum step size of 1 MHz. It is preferred to measure insertion loss at the same frequency intervals as NEXT Loss in order to provide a more accurate calculation of the Attenuation-to-Crosstalk ratio (ACR) parameter. Minimum test results documentation (summary results): Identify the worst wire pair (1 of 4 possible). The test results for the worst wire pair must show the highest attenuation value measured (worst case), the frequency at which this worst case value occurs, and the test limit value at this frequency.
4. **NEXT Loss**
Pair-to-pair near-end crosstalk loss (abbreviated as NEXT Loss) shall be tested for each wire pair combination from each end of the link (a total of 12 pair combinations). This parameter is to be measured from 1 through 250 MHz NEXT Loss measures the crosstalk disturbance on a wire pair at the end from which the disturbance signal is transmitted (near-end) on the disturbing pair. The maximum step size for NEXT Loss measurements shall not exceed the maximum step size defined in the Cabling Test Standard as shown in Table 2. Minimum test results documentation (summary results): Identify the wire pair combination that exhibits the worst case NEXT margin *and* the wire pair combination that exhibits the worst value of NEXT (worst case). NEXT is to be measured from each end of the link-under-test. These wire pair combinations must be identified for the tests performed from each end. Each reported case should include the frequency at which it occurs as well as the test limit value at this frequency.

Table 1, Maximum frequency step size as defined in ANSI/TIA-1152

Frequency Range (MHz)	Maximum Step size (MHz)
1 – 31.25	0.15
31.26 – 100	0.25
100 – 250	0.50

PS NEXT Loss:

Power Sum NEXT Loss shall be evaluated and reported for each wire pair from both ends of the link under-test (a total of eight results). PS NEXT Loss captures the combined near-end crosstalk effect (statistical) on a wire pair when all other pairs actively transmit signals. Like NEXT this test parameter must be evaluated from 1 through 250 MHz and the step size may not exceed the maximum step size defined in the Cabling Test Standard as shown in Table 2. Minimum test results documentation (summary results): Identify the wire pair that exhibits the worst-case margin and the wire pair that exhibits the worst value for PS NEXT. These wire pairs must be identified for the tests performed from each end. Each reported case should include the frequency at which it occurs as well as the test limit value at this frequency.

6. ACR-F Loss, pair-to-pair:

Attenuation Crosstalk Ratio Far-end is calculated from the pair-to-pair FEXT Loss. It shall be measured for each wire-pair combination from both ends of the link under-test. FEXT Loss measures the crosstalk disturbance on a wire pair at the opposite end (far-end) from which the transmitter emits the disturbing signal on the disturbing pair. FEXT is measured to compute ACR-F Loss that must be evaluated and reported in the test results. ACR-F measures the relative strength of the far-end crosstalk disturbance relative to the attenuated signal that arrives at the end of the link. This test yields 24 wire pair combinations. ACR-F is to be measured from 1 through 250 MHz and the maximum step size for FEXT Loss measurements shall not exceed the maximum step size defined in the standard as in Table 2. Minimum test results documentation (summary results): Identify the wire pair combination that exhibits the worst-case margin and the wire pair combination that exhibits the worst value for ACR-F. These wire pairs must be identified for the tests performed from each end. Each reported case should include the frequency at which it occurs as well as the test limit value at this frequency.

7. PS ACR-F Loss:

Power Sum Attenuation Crosstalk Ratio Far-end is a calculated parameter that combines the effect of the FEXT disturbance from three wire pairs on the fourth one. This test yields eight wire-pair combinations. Each wire-pair is evaluated from 1 through 250 MHz in frequency increments that do not exceed the maximum step size defined in the standard as shown in Table 2. Minimum test results documentation (summary results): Identify the wire pair that exhibits the worst pair combinations must be identified for the tests performed from each end. Each reported case should include the frequency at which it occurs as well as the test limit value at this frequency.

8. Return Loss:

Return Loss (RL) measures the total energy reflected on each wire pair. Return Loss is to be measured from both ends of the link-under-test for each wire pair. This parameter is also to be measured from 1 through 250 MHz in frequency increments that do not exceed the maximum step size defined in the Cabling Test Standard as shown in Table 2. Minimum test results documentation (summary results): Identify the wire pair that exhibits the worst-case margin and the wire pair that exhibits the worst value for Return Loss. These wire pairs must be identified for the tests performed from each end. Each reported case should include the frequency at which it occurs as well as the test limit value at this frequency.

9. Propagation Delay:

Propagation delay is the time required for the signal to travel from one of the link to the other. This measurement is to be performed for each of the four wire pairs. Minimum test results documentation (summary results): Identify the wire pair with the worst-case propagation delay. The report shall include the propagation delay value measured as well as the test limit value.

10. Delay Skew: [as defined in the Cabling Test Standard; Section 6.2.19]. This parameter shows the difference in propagation delay between the four wire pairs. The pair with the shortest propagation delay is the reference pair with a delay skew value of zero. Minimum test results documentation (summary results): Identify the wire pair with the worst-case propagation delay (the longest propagation delay). The report shall include the delay skew value measured as well as the test limit value.**C. Test Result Documentation:**

1. The test results/measurements shall be transferred into a Windows™-based database utility that allows for the maintenance, inspection and archiving of these test records. A guarantee must be made that the measurement results are transferred to the PC unaltered, i.e., “as saved in the tester” at the end of each test and that these results cannot be modified at a later time.
2. The database for the completed job shall be stored and delivered on CD-ROM or DVD including the software tools required to view, inspect, and print any selection of test reports.
3. A paper copy of the test results is required at the discretion of the WUSM/BJC/TFC representative. If a paper copy is requested, it will contain the following:

- a. The identification of the link in accordance with the WUSM/BJC/TFC naming convention.
 - b. The overall Pass/Fail evaluation of the link-under-test including the NEXT Headroom (overall worst case) number.
 - c. The date and time the test results were saved in the memory of the tester.
4. General Information to be provided in the electronic data base with the test results information for each link:
- a. The identification of the customer site as specified by the WUSM/BJC/TFC representative.
 - b. The identification of the link in accordance with the naming convention defined in the overall system documentation.
 - c. The overall Pass/Fail evaluation of the link-under-test.
 - d. The name of the test limit selected to execute the stored test results.
 - e. The cable type and the value of NVP used for length calculations.
 - f. The date and time the test results were saved in the memory of the tester.
 - g. The brand name, model and serial number of the tester.
 - h. The identification of the tester interface.
 - i. The revision of the tester software and the revision of the test limits database in the tester.
 - j. The test results information must contain information on each of the required test parameters that are listed in Section B and as further detailed below under paragraph C5.
5. The detailed test results data to be provided in the electronic database and will contain the following information:

For each of the frequency-dependent test parameters, the value measured at every frequency during the test is stored. The PC-resident database program must be able to process the stored results to display and print a color graph of the measured parameters. The PC-resident software must also provide a summary numeric format in which some critical information is provided numerically as defined by the summary results (minimum numeric test results documentation) as outlined above for each of the test parameters.

Length: Identify the wire-pair with the shortest electrical length, the value of the length rounded to the nearest 0.1 m and the test limit value.

Propagation delay: Identify the pair with the shortest propagation delay, the value measured in nanoseconds (ns) and the test limit value.

Delay Skew: Identify the pair with the largest value for delay skew, the value calculated in nanoseconds (ns) and the test limit value.

Insertion Loss (Attenuation): Minimum test results documentation as explained in Section B for the worst pair.

Return Loss: Minimum test results documentation as explained in Section B for the worst pair as measured from each end of the link.

NEXT, ACR-F: Minimum test results documentation as explained in Section B for the worst pair combination as measured from each end of the link.

PS NEXT and PS ACR-F: Minimum test results documentation as explained in Section B for the worst pair as measured from each end of the link.

Category 6A Installations:

A. General Requirements

13. Every cabling link in the installation shall be tested for:
- a. Wire Map
 - b. Length
 - c. Insertion Loss
 - d. NEXT Loss
 - e. PS NEXT Loss
 - f. ACR-F Loss
 - g. PS ACR-F Loss
 - h. Return Loss
 - i. Propagation Delay

j. Delay Skew

In accordance with the field test specifications defined in ANSI/TIA-568-C.2 “*Commercial Balanced Twisted-Pair Telecommunications Cabling and Components Standard*”. This document will be referred to as the “TIA Cat 6A Standard.”

14. In addition to testing the “In-link” performance parameters detailed in A.1 above, Alien Crosstalk testing or “Between-link” testing shall be carried out in accordance with Section 4.7 of ANSI/TIA-1152. Alien crosstalk testing includes the PS ANEXT and PS AACR-F (Power sum alien attenuation-to-crosstalk ratio from the far end) performance parameters. The standards refer to the link-under-test for Alien Crosstalk as the *disturbed* link.
15. PS ANEXT and PS AACR-F shall meet or exceed the limits defined in Section 6 of the TIA Cat 6A Standard.
 - a. Selection of disturbed (victim) links:

Installation size (No. of total links)	Sample size (No. of links to test)
3 – 33	100%
34 – 3,200	33
3,201 – 35,000	126
35,001 – 150,000	201
150,001 – 500,000	315

- b. Choose short, medium and long links equally.
 - c. Selection of disturber links. Select all of the links that are in the same cable bundle and the most consistently positioned relative to the disturbed link as disturbing links.
16. If the margin of PS ANEXT and PS AACR-F exceeds 5 dB for the first three short, medium and long links (nine in total), further alien crosstalk testing can be discontinued.
17. The installed twisted-pair horizontal links shall be tested from the IDF in the telecommunications room to the telecommunication wall outlet in the work area for compliance with the “*Permanent Link*” performance specification as defined in the TIA Cat 6A Standard.
18. One hundred percent of the installed cabling links must pass the requirements of the standards mentioned in A.1 above and as further detailed in Section B. Any failing link must be diagnosed and corrected. The corrective action shall be followed with a new test to prove that the corrected link meets the performance requirements. The final and passing result of the tests for all links shall be provided in the test results documentation in accordance with Section C below.
19. Trained technicians who have successfully attended an appropriate training program and have obtained a certificate as proof thereof shall execute the tests. Appropriate training programs include but are not limited to installation certification programs provided by BICSI or the ACP (Association of Cabling Professionals).
20. The test equipment (tester) shall comply with the accuracy requirements for level IIIe field testers as defined in ANSI/TIA-1152. The tester including the appropriate interface adapter must meet the specified accuracy requirements. The accuracy requirements for the permanent link test configuration (baseline accuracy *plus* adapter contribution) are specified in Table 4 of ANSI/TIA-1152 (Table 4 in this TIA document also specifies the accuracy requirements for the Channel configuration).
21. The RJ45 test plug shall fall within the values specified in ANSI/TIA-568-C Annex C for NEXT, FEXT and Return Loss.
22. The tester shall be within the calibration period recommended by the vendor in order to achieve the vendor-specified measurement accuracy.
23. The tester interface adapters must be of high quality and the cable shall not show any twisting or kinking resulting from coiling and storing of the tester interface adapters. In order to deliver optimum accuracy, preference is given to a permanent link interface adapter for the tester that can be calibrated to extend the reference plane of the Return Loss measurement to the permanent link interface. The contractor shall provide proof that the interface has been calibrated within the period recommended by the vendor. To ensure that normal handling on the job does not cause measurable Return Loss change, the adapter cord cable shall not be of twisted-pair construction.
24. The Pass or Fail condition for the link-under-test is determined by the results of the required individual tests (detailed in Section 4.2.2 of ANSI/TIA-1152). Any Fail or Fail* result yields a Fail for the link-under-test. In order to achieve an overall Pass condition, the results for each individual test parameter must Pass or Pass*.

25. A Pass or Fail result for each parameter is determined by comparing the measured values with the specified test limits for that parameter. The test result of a parameter shall be marked with an asterisk (*) when the result is closer to the test limit than the accuracy of the field tester. The field tester manufacturer must provide documentation as an aid to interpret results marked with asterisks. To which extent '*' results shall determine approval or disapproval of the element under test shall be defined in the relevant detail specification, or agreed on as a part of a contractual specification.

Optional Requirements:

26. A WUSM/BJC/TFC representative shall be invited to witness field testing. The representative shall be notified of the start date of the testing phase five business days before testing commences.
27. A WUSM/BJC/TFC representative will select a random sample of 5% of the installed links. The representative (or his authorized delegate) shall test these randomly selected links and the results are to be stored in accordance with the prescriptions in Section I.C. The results obtained shall be compared to the data provided by the installation contractor. If more than 2% of the sample results differ in terms of the pass/fail determination, the installation contractor under supervision of the end-user representative shall repeat 100% testing and the cost shall be borne by the installation contractor.

B. Performance Test Parameters

The test parameters for Cat 6A are defined in the TIA Cat 6A standard. The test of each link shall contain all of the following parameters as detailed below. In order to pass the test, all measurements (at each frequency in the range from 1 MHz through 500 MHz) must meet or exceed the limit value determined in the above-mentioned standard.

11. Wire Map:

Shall report pass if the wiring of each wire-pair from end to end is determined to be correct. The Wire Map results shall include the continuity of the shield connection if present.

12. Length:

The field tester shall be capable of measuring length of all pairs of a basic link or channel based on the propagation delay measurement and the average value for NVP. The physical length of the link shall be calculated using the pair with the shortest electrical delay. This length figure shall be reported and shall be used for making the Pass/Fail decision. The Pass/Fail criteria are based on the maximum length allowed for the Permanent Link configuration (90 meters – 295 feet) plus 10% to allow for the variation and uncertainty of NVP.

13. Insertion Loss (Attenuation):

Insertion Loss is a measure of signal loss in the permanent link or channel. The term “Attenuation” has been used to designate “Insertion Loss.” Insertion Loss shall be tested from 1 MHz through 500 MHz in maximum step size of 1 MHz. It is preferred to measure insertion loss at the same frequency intervals as NEXT Loss in order to provide a more accurate calculation of the Attenuation-to-Crosstalk ratio (ACR) parameter. Minimum test results documentation (summary results): Identify the worst wire pair (1 of 4 possible). The test results for the worst wire pair must show the highest attenuation value measured (worst case), the frequency at which this worst case value occurs, and the test limit value at this frequency.

14. NEXT Loss:

Pair-to-pair near-end crosstalk loss (abbreviated as NEXT Loss) shall be tested for each wire pair combination from each end of the link (a total of 12 pair combinations). This parameter is to be measured from 1 through 500 MHz NEXT Loss measures the crosstalk disturbance on a wire pair at the end from which the disturbance signal is transmitted (near-end) on the disturbing pair. The maximum step size for NEXT Loss measurements shall not exceed the maximum step size defined in the standard as shown in Table 2. Minimum test results documentation (summary results): Identify the wire pair combination that exhibits the worst case NEXT margin **and** the wire pair combination that exhibits the worst value of NEXT (worst case). NEXT is to be measured from each end of the link-under-test. These wire pair combinations must be identified for the tests performed from each end. Each reported case should include the frequency at which it occurs as well as the test limit value at this frequency.

Table 2, Maximum frequency step size as defined in ANSI/TIA-1152

Frequency Range (MHz)	Maximum Step size (MHz)
-----------------------	-------------------------

1 – 31.25	0.15
31.26 – 100	0.25
100 – 250	0.50
250 – 500	1.00

15. **PS NEXT Loss:**

Power Sum NEXT Loss shall be evaluated and reported for each wire pair from both ends of the link under-test (a total of eight results). PS NEXT Loss captures the combined near-end crosstalk effect (statistical) on a wire pair when all other pairs actively transmit signals. Like NEXT this test parameter must be evaluated from 1 through 500 MHz and the step size may not exceed the maximum step size defined in the standard as shown in Table 2. Minimum test results documentation (summary results): Identify the wire pair that exhibits the worst-case margin and the wire pair that exhibits the worst value for PS NEXT. These wire pairs must be identified for the tests performed from each end. Each reported case should include the frequency at which it occurs as well as the test limit value at this frequency.

16. **ACR-F, pair-to-pair:**

Attenuation Crosstalk Ratio Far-end is calculated from the pair-to-pair FEXT Loss. It shall be measured for each wire-pair combination from both ends of the link under-test. FEXT Loss measures the crosstalk disturbance on a wire pair at the opposite end (far-end) from which the transmitter emits the disturbing signal on the disturbing pair. FEXT is measured to compute ACR-F Loss that must be evaluated and reported in the test results. ACR-F measures the relative strength of the far-end crosstalk disturbance relative to the attenuated signal that arrives at the end of the link. This test yields 24 wire pair combinations. ACR-F is to be measured from 1 through 500 MHz and the maximum step size for FEXT Loss measurements shall not exceed the maximum step size defined in the standard as in Table 2. Minimum test results documentation (summary results): Identify the wire pair combination that exhibits the worst-case margin and the wire pair combination that exhibits the worst value for ACR-F. These wire pairs must be identified for the tests performed from each end. Each reported case should include the frequency at which it occurs as well as the test limit value at this frequency.

17. **PS ACR-F Loss:**

Power Sum Attenuation Crosstalk Ratio Far-end is a calculated parameter that combines the effect of the FEXT disturbance from three wire pairs on the fourth one. This test yields eight wire-pair combinations. Each wire-pair is evaluated from 1 through 500 MHz in frequency increments that do not exceed the maximum step size defined in the standard as shown in Table 2. Minimum test results documentation (summary results): Identify the wire pair that exhibits the worst pair combinations must be identified for the tests performed from each end. Each reported case should include the frequency at which it occurs as well as the test limit value at this frequency.

18. **Return Loss:**

Return Loss (RL) measures the total energy reflected on each wire pair. Return Loss is to be measured from both ends of the link-under-test for each wire pair. This parameter is also to be measured from 1 through 500 MHz in frequency increments that do not exceed the maximum step size defined in the standard as shown in Table 2. Minimum test results documentation (summary results): Identify the wire pair that exhibits the worst-case margin and the wire pair that exhibits the worst value for Return Loss. These wire pairs must be identified for the tests performed from each end. Each reported case should include the frequency at which it occurs as well as the test limit value at this frequency.

19. **Propagation Delay:**

Propagation delay is the time required for the signal to travel from one of the link to the other. This measurement is to be performed for each of the four wire pairs. Minimum test results documentation (summary results): Identify the wire pair with the worst-case propagation delay. The report shall include the propagation delay value measured as well as the test limit value.

20. **Delay Skew:** [as defined in the TIA Cat 6A Standard; Section 6.2.19] This parameter shows the difference in propagation delay between the four wire pairs. The pair with the shortest propagation delay is the reference pair with a delay skew value of zero. Minimum test results documentation (summary results): Identify the wire pair with the worst-case propagation lay (the longest propagation delay). The report shall include the delay skew value measured as well as the test limit value.

21. **PS ANEXT:**

Pair-to-pair Alien NEXT (ANEXT) contributions is measured by applying the stimulus signal at the near end to

one wire pair of a disturbing link and measuring the coupled signal at the near end of a wire pair in a disturbed link. This process is repeated for every wire pair in a disturbing link. The PS ANEXT for each wire pair in a disturbed link is obtained by the power sum addition of all the pair-to-pair ANEXT results to that wire pair from all wire pairs in disturbing links. All the links that are bundles with the disturbed link need to be included as disturbing links. In addition, links that are terminated in adjacent positions in a patch panel or interconnect panel should also be included as disturbing links in this test.

Minimum test results documentation (summary results): Identify the wire pair that exhibits the worst-case margin and the wire pair that exhibits the worst value for PS ANEXT. These wire pairs must be identified for the tests performed from each end. Each reported case should include the frequency at which it occurs as well as the test limit value at this frequency.

22. **PS AACR-F:**

The pair-to-pair Alien Far End crosstalk (AFEXT) contributions is measured by applying the signal at the near end to one wire pair of a disturbing channel or permanent link and measuring the coupled signal at the far end of a wire pair in a disturbed channel or permanent link. This process is repeated for every wire pair in a disturbing link and for all links in close proximity. A normalization, which is dependent on the relative length of disturbing and disturbed link, is applied to each pair-to-pair alien FEXT measurement. Then the PS Alien Attenuation-to-Crosstalk Ratio from the Far end (PS AACR-F) for each wire pair in a disturbed channel or permanent link is obtained by the power sum addition of all the normalized pair-to-pair far end alien crosstalk results to that wire pair from all wire pairs in disturbing links in close proximity.

Minimum test results documentation (summary results): Identify the wire pair that exhibits the worst-case margin and the wire pair that exhibits the worst value for PS AACR-F. If the link or channel connects two patch panels (data center), these wire pairs must be identified for the tests performed from both ends. Each reported case should include the frequency at which it occurs as well as the test limit value at this frequency.

C. Test Result Documentation:

6. The test results/measurements shall be transferred into a Windows™-based database utility that allows for the maintenance, inspection and archiving of these test records. A guarantee must be made that the measurement results are transferred to the PC unaltered, i.e., “as saved in the tester” at the end of each test and that these results cannot be modified at a later time.
7. The database for the completed job shall be stored and delivered on CD-ROM or DVD including the software tools required to view, inspect, and print any selection of test reports.
8. A paper copy of the test results is required at the discretion of the WUSM/BJC/TFC representative. If requested, it shall list all the links that have been tested with the following summary information:
 - d. The identification of the link in accordance with the naming convention defined in the overall system documentation.
 - e. The overall Pass/Fail evaluation of the link-under-test including the NEXT Headroom (overall worst case) number.
 - f. The date and time the test results were saved in the memory of the tester.
9. General Information to be provided in the electronic data base with the test results information for each link:
 - k. The identification of the customer site as specified by the end-user.
 - l. The identification of the link in accordance with the naming convention defined in the overall system documentation.
 - m. The overall Pass/Fail evaluation of the link-under-test.
 - n. The name of the standard selected to execute the stored test results.
 - o. The cable type and the value of NVP used for length calculations.
 - p. The date and time the test results were saved in the memory of the tester.
 - q. The brand name, model and serial number of the tester.
 - r. The identification of the tester interface.
 - s. The revision of the tester software and the revision of the test standards database in the tester.
 - t. The test results information must contain information on each of the required test parameters that are listed in Section B and as further detailed below under paragraph C5 & C6.
10. In-link (In-Channel) detailed test results. The detailed test results data to be provided in the electronic database for must contain the following information:

For each of the frequency-dependent test parameters, the value measured at every frequency during the test is stored. The PC-resident database program must be able to process the stored results to display and print a color

graph of the measured parameters. The PC-resident software must also provide a summary numeric format in which some critical information is provided numerically as defined by the summary results (minimum numeric test results documentation) as outlined above for each of the test parameters.

Length: Identify the wire-pair with the shortest electrical length, the value of the length rounded to the nearest 0.1 m and the test limit value.

Propagation delay: Identify the pair with the shortest propagation delay, the value measured in nanoseconds (ns) and the test limit value.

Delay Skew: Identify the pair with the largest value for delay skew, the value calculated in nanoseconds (ns) and the test limit value.

Insertion Loss (Attenuation): Minimum test results documentation as explained in Section B for the worst pair.

Return Loss: Minimum test results documentation as explained in Section B for the worst pair as measured from each end of the link.

NEXT, ACR-F: Minimum test results documentation as explained in Section B for the worst pair combination as measured from each end of the link.

PS NEXT and PS ACR-F: Minimum test results documentation as explained in Section B for the worst pair as measured from each end of the link.

11. Between-Link (Between-Channel) Test Results Data:

A test report shall be provided for each disturbed link included in the Alien Crosstalk sample test. This test report must contain:

- a. PS ANEXT results at each frequency (See Table 1) for each wire pair in a victim link as well as the PS ANEXT results for the average of these four wire pairs. The worst case margin and the worst values shall be provided for each wire pair and the average of the four wire pairs. PS ANEXT shall be measured and tested from the end of the link or channel where all cables are terminated at a distribution panel. In case the cabling runs from panel to panel (data center) where the worst case PS ANEXT margin is less than 2 dB, the PS ANEXT test results for each disturbed link shall be collected and saved from both ends (both panels) of the disturbed link.
- b. PS AACR-F results at each frequency tested (See Table 1) for each wire pair in a disturbed link as well as the PS AACR-F results for the average of the four wire pairs. The worst case margin and the worst values shall be provided for each wire pair and the average of the four wire pairs. PS AACR-F only needs to be measured and tested from one end of the link or channel. Connect the main DTX-1800 unit (measurement of PS AACR-F disturbance) to the disturbed link or channel at the end where all cabling links are terminated at a distribution panel. Select End 1 in the AxTalk Analyzer Software.

SCOPE:

This Section includes the minimum requirements for the test certification, identification and administration of backbone and horizontal optical fiber cabling.

This Section includes minimum requirements for:

Fiber optic test instruments

Fiber optic testing

Identification

Labels and labeling

Administration

Test results documentation

As-built drawings

Testing shall be carried out in accordance with this document. This includes testing the attenuation and polarity of the installed cable plant with an optical loss test set (OLTS) and the installed condition of the cabling system and its components with an optical time domain reflectometer (OTDR). The condition of the fiber endfaces shall also be verified.

Testing shall be performed on each cabling link (connector to connector).

All tests shall be documented including OLTS dual wavelength attenuation measurements for multimode and single mode links and channels and OTDR traces and event tables for multimode and single mode links and channels.

Optionally documentation shall also include optical length measurements and pictures of the connector endface.

QUALITY ASSURANCE:

All testing procedures and field-test instruments shall comply with applicable requirements of:

ANSI Z136.2, ANS For Safe Use Of Optical Fiber Communication Systems Utilizing Laser Diode And LED Sources

ANSI/EIA/TIA-455-50B, Light Launch Conditions For Long-Length Graded-Index Optical Fiber Spectral Attenuation Measurements

ANSI/TIA/EIA-455-59A, Measurement of Fiber Point Discontinuities Using an OTDR.

ANSI/TIA/EIA-455-60A, Measurement of Fiber or Cable Length Using an OTDR.

ANSI/TIA/EIA-455-61A, Measurement of Fiber or Cable Attenuation Using an OTDR.

ANSI/TIA/EIA-526-7, Optical Power Loss Measurements of Installed Single mode Fiber Cable Plant.

ANSI/TIA/EIA-526-14-A, Optical Power Loss Measurements of Installed Multimode Fiber Cable Plant.

ANSI/TIA-568-C.0, Generic Telecommunications Cabling for Customer Premises.

ANSI/TIA-568-C.3, Optical Fiber Cabling Components Standard.

ANSI/TIA/EIA-606-A, Administration Standard for Commercial Telecommunications Infrastructure, including the requirements specified by the customer, unless the customer specifies their own labeling requirements.

Trained technicians who have successfully attended an appropriate training program, which includes testing with an OLTS and an OTDR and have obtained a certificate as proof thereof shall execute the tests. These certificates may have been issued by any of the following organizations or an equivalent organization:

Manufacturer of the fiber optic cable and/or the fiber optic connectors.

Manufacturer of the test equipment used for the field certification.

Training organizations (e.g., BICSI, A Telecommunications Association headquarters in Tampa, Florida; ACP [Association of Cabling Professionals™] Cabling Business Institute located in Dallas, Texas)

SUBMITTALS

Manufacturers catalog sheets and specifications for fiber optic field-test instruments including optical loss test sets (OLTS; power meter and source), optical time domain reflectometer (OTDR) and inspection scope.

A schedule (list) of all optical fibers to be tested.

Sample test reports.

Acceptance of test results:

Unless otherwise specified by the Owner or the Owners representative, each cabling link shall be in compliance with the following test limits:

Optical loss testing:

Multimode and Single mode links

The link attenuation shall be calculated by the following formulas as specified in ANSI/TIA-568-C.0.

$$\text{Link Attenuation (dB)} = \text{Cable_Attn (dB)} + \text{Connector_Attn (dB)} + \text{Splice_Attn (dB)}$$

$$\text{Cable_Attn (dB)} = \text{Attenuation_Coefficient (dB/km)} * \text{Length (Km)}$$

$$\text{Connector_Attn (dB)} = \text{number_of_connector_pairs} * \text{connector_loss (dB)}$$

$$\text{Maximum allowable connector_loss} = 0.50 \text{ dB}$$

$$\text{Splice_Attn (dB)} = \text{number_of_splices} * \text{splice_loss (dB)}$$

$$\text{Maximum allowable splice_loss} = 0.3 \text{ dB}$$

The values for the Attenuation Coefficient (dB/km) are listed in the table below:

Type of Optical Fiber	Wavelength (nm)	Attenuation coefficient (dB/km)	Wavelength (nm)	Attenuation coefficient (dB/km)
Multimode 62.5/125 μm	850	3.5	1300	1.5
Multimode 50/125 μm	850	3.5	1300	1.5

Single-mode (Inside plant)	1310	1.0	1550	1.0
Single-mode (Outside plant)	1310	0.5	1550	0.5

OTDR testing:

Reflective events (connections) shall not exceed 0.50 dB.

Non-reflective events (splices) shall not exceed 0.3 dB.

Magnified endface inspection:

Fiber connections shall be visually inspected for endface quality.

Scratched, pitted or dirty connectors shall be diagnosed and corrected.

All installed cabling links and channels shall be field-tested and pass the test requirements and analysis as described in Part 3. Any link or channel that fails these requirements shall be diagnosed and corrected. Any corrective action that must take place shall be documented and followed with a new test to prove that the corrected link or channel meets performance requirements. The final and passing result of the tests for all links and channels shall be provided in the test results documentation in accordance with Part 3.

Acceptance of the test results shall be given in writing after the project is fully completed and tested in accordance with Contract Documents and to the satisfaction of the WUSM/TFC/BJC representative.

Note: High Bandwidth applications such as 1000BASE-SX, 10GBASE-S, and FC1200 impose stringent channel loss limits. Where practical, certification should consider loss length limits that meet maximum channel (transmitter to receiver) loss.

Performance specification for MM fiber at 850 nm

Fiber Type		Bandwidth	1000BASE-SX		10GBASE-SR		FibreChannel 1200-MX-SN-I	
	μm	(MHz•Km)	Length (m)	Loss (dB)	Length (m)	Loss (dB)	Length (m)	Loss (dB)
OM 1	62.5	200	275	2.38	33	2.5	33	2.4
OM 2	50	500	550	3.56	82	2.3	82	2.2
OM 3	50	2000	1000	3.56	300	2.6	300	2.6

– PRODUCTS:

Optical Fiber Cable Testers:

The field-test instrument shall be within the calibration period recommended by the manufacturer.

Optical loss test set (OLTS):

Multimode optical fiber light source:

Provide dual LED light sources with central wavelengths of 850 nm (± 30 nm) and 1300 nm (± 20 nm)

Output power of -20 dBm minimum.

The light source shall meet the launch requirements of ANSI/EIA/TIA-455-50B, Method A. This launch condition can be achieved either within the field test equipment or by use of an external mandrel wrap (as described in clause E.7 of ANSI/TIA-568-C.0) with a Category 1 light source.

Single mode optical fiber light source:

Provide dual laser light sources with central wavelengths of 1310 nm (± 20 nm) and 1550 nm (± 20 nm).

Output power of -10 dBm minimum.

Power Meter:

Provide 850 nm, 1300/1310 nm, and 1550 nm wavelength test capability.

Power measurement uncertainty of ± 0.25 dB.

Store reference power measurement.

Save at least 100 results in internal memory.

PC interface (serial or USB).

Optional length measurement:

It is preferable to use an OLTS that is capable of measuring the optical length of the fiber using time-of-flight techniques.

Optical Time Domain Reflectometer (OTDR):

Shall have a bright, color transmissive LCD display with backlight.

Shall have rechargeable Li-Ion battery for 8 hours of normal operation.

Weight with battery and module of not more than 4.5 lb and volume of not more than 200 in³.

Internal non-volatile memory and removable memory device with at least 16 MB capacity for results storage.

Serial and USB ports to transfer data to a PC.

Multimode OTDR:

Wavelengths of 850 nm (± 20 nm) and 1300 nm (± 20 nm).

Event deadzones of 3.7 m maximum at 850 nm and 1300 nm.

Attenuation deadzones of 10 m maximum at 850 nm and 13 m maximum at 1300 nm.

Distance range not less than 2000 m.

Dynamic range at least 10 dB at 850 nm and 1300 nm

Single mode OTDR:

Wavelengths of 1310 nm (± 20 nm) and 1550 nm (± 20 nm).

Event dead zones of 3.5 m maximum at 1310 nm and 1550 nm.

Attenuation deadzones of 10 m maximum at 1310 nm and 12 m maximum at 1550 nm.

Distance range not less than 10000 m.

Dynamic range at least 10 dB at 1310 nm and 1550 nm:

Fiber Microscope:

Magnification of 200X or 400X for end face inspection.

Required requirements:

Video camera systems are preferred.

Camera probe tips that permit inspection through adapters are preferred.

It is preferable to use test equipment capable of saving and reporting the end face image.

Integrated OLTS, OTDR and fiber microscope:

Test equipment that combines into one instrument an OLTS, an OTDR and a fiber microscope may be used.

Identification:

Labels:

Shall meet the legibility, defacement, exposure and adhesion requirements of UL 969.

Shall be preprinted using a mechanical means of printing (e.g., laser printer).

Where insert type labels are used provide clear plastic cover over label.

Provide plastic warning tape 6 inches wide continuously printed and bright colored 18" above all direct buried services, underground conduits and duct-banks.

Acceptable Manufacturers:

Panduit

Silver Fox

W.H. Brady

NORDX/CDT

Tyco

Avaya

d-Tools

Brothers

Administration:

Administration of the documentation shall include test results of each fiber link and channel as found in the WUSM/TFC/BJC low voltage voice and data pathways and spaces standard.

The test result information for each link shall be recorded in the memory of the field-test instrument upon completion of the test.

The test result records saved within the field-test instrument shall be transferred into a Windows™-based database utility that allows for the maintenance, inspection and archiving of these test records.

EXECUTION:

General:

All tests performed on optical fiber cabling that use a laser or LED in a test set shall be carried out with safety precautions in accordance with ANSI Z136.2.

All outlets, cables, patch panels and associated components shall be fully assembled and labeled prior to field-testing. Any testing performed on incomplete systems shall be redone on completion of the work.

OPTICAL FIBER CABLE TESTING:

Field-test instruments shall have the latest available software and firmware installed.

Link and channel test results from the OLTS and OTDR shall be recorded in the test instrument upon completion of each test for subsequent uploading to a PC in which the administrative documentation (reports) may be generated.

Testing shall be performed on each cabling segment (connector to connector).

Testing of the cabling shall be performed using high-quality test cords of the same fiber type as the cabling under test. The test cords for OLTS testing shall be between 1 m and 5 m in length. The test cords for OTDR testing shall be approximately 100 m for the launch cable and at least 25 m for the receive cable.

Optical loss testing:

Backbone link:

Multimode backbone links shall be tested at 850 nm and 1300 nm in accordance with ANSI/EIA/TIA-526-14A, Method B, One Reference Jumper or the equivalent method.

Single mode backbone links shall be tested at 1310 nm and 1550 nm in accordance with ANSI/TIA/EIA-526-7, Method A.1, One Reference Jumper or the equivalent method.

Link attenuation does not include any active devices or passive devices other than cable, connectors, and splices, i.e. link attenuation does not include such devices as optical bypass switches, couplers, repeaters, or optical amplifiers.

Use the One Reference Jumper Method specified by ANSI/TIA/EIA-526-14A, Method B and ANSI/TIA/EIA-526-7, Method A.1 or the equivalent method. The user shall follow the procedures established by these standards or application notes to accurately conduct performance testing.

OTDR Testing:

Fiber links shall be tested at the appropriate operating wavelengths for anomalies and to ensure uniformity of cable attenuation and connector insertion loss.

Multimode: 850 nm and 1300 nm

Single mode: 1310 nm and 1550 nm

Each fiber link and channel shall be tested in both directions.

A launch cable shall be installed between the OTDR and the first link connection.

A receive cable shall be installed after the last link connection.

Length Measurement:

The length of each fiber shall be recorded.

It is preferable that the optical length be measured using an OLTS or OTDR.

Polarity Testing:

Paired duplex fibers in multi-fiber cables shall be tested to verify polarity in accordance with Clause E.5.3 of ANSI/TIA-568-C.0. The polarity of the paired duplex fibers shall be verified using an OLTS.

Identification:

Labeling:

Labeling shall conform to the requirements specified within ANSI/TIA/EIA-606-A or to the requirements specified by the WUSM/TFC/BJC representative.

Administration

Test results documentation:

Test results saved within the field-test instrument shall be transferred into a Windows™-based database utility that allows for the maintenance, inspection and archiving of the test records. These test records shall be uploaded to the PC unaltered, i.e., “as saved in the field-test instrument”. The file format, CSV (comma separated value), does not provide adequate protection of these records and shall not be used.

The test results documentation shall be available for inspection by the WUSM/TFC/BJC representative during the installation period and shall be passed to the Owner's representative within 5 working days of completion of tests on cabling served by a telecommunications room or of backbone cabling. The installer shall retain a copy to aid preparation of as-built information.

The database for the complete project, including twisted-pair copper cabling links, if applicable, shall be stored and delivered on CD-ROM prior to WUSM/TFC/BJC's acceptance of the building. This CD-ROM shall include the software tools required to view, inspect, and print any selection of the test reports.

Circuit IDs reported by the test instrument should match the specified label ID (see 0 of this Section).

The detailed test results documentation data is to be provided in an electronic database for each tested optical fiber and shall contain the following information.

The identification of the customer site as specified by the end-user.

The name of the test limit selected to execute the stored test results.

The name of the personnel performing the test.

The date and time the test results were saved in the memory of the tester.

The manufacturer, model and serial number of the field-test instrument.

The version of the test software and the version of the test limit database held within the test instrument.

The fiber identification number.

The length for each optical fiber.

Optionally the index of refraction used for length calculation when using a length capable OLTS

Test results to include OLTS attenuation link and channel measurements at the appropriate wavelength(s) and the margin (difference between the measured attenuation and the test limit value).

Test results to include OTDR link and channel traces and event tables at the appropriate wavelength(s).

The length for each optical fiber as calculated by the OTDR.

The overall Pass/Fail evaluation of the link-under-test for OLTS and OTDR measurements.

Optional at the discretion of the WUSM/TFC/BJC representative :

A pass/fail status of the end-face based upon visual inspection.

Record copy and as-built drawings:

Provide record copy drawings periodically through out the project as requested by the Construction Manager or Owner, and at end of the project on CD-ROM. Record copy drawings at the end of the project shall be in CAD format and include notations reflecting the as built conditions of any additions to or variation from the drawings provided such as, but not limited to cable paths and termination point. CAD drawings are to incorporate test data imported from the test instruments.

The as-built drawings shall include, but are not limited to block diagrams, frame and cable labeling, cable termination points, equipment room layouts and frame installation details. The as-builts shall include all field changes made up to construction completion:

Field directed changes to pull schedule.

Field directed changes to cross connect and patching schedule.

Horizontal cable routing changes.

Backbone cable routing or location changes.

Associated detail drawings.

Appendix O: Manufacturer Part Numbers

	Manufacturer	Part Number	Item Description
1.	CPI	55053-703	Standard universal 7', 19" free standing 2-post rack.
2.	CPI	40160-072	Vertical Buss Bar
3.	CPI	40157-001	Insulator blocks and stand offs for buss bar
4.	CPI	66353-703	Standard 6" Deep 7' Rack Black
5	CPI	40095-703	MCS-EFX extended finger, 6" wide x 7' high double sided vertical management
6.	CPI	SK8714-719	3RMU extended finger single sided horizontal management
7	CPI	SK -6681-719	2RMU Extended Fingers Horizontal Wire manager
8	CPI	30095-703	6" vertical wire manager
9	CPI	40096-703	MCS-EFX extended fingers 10" wide 7' high double sided vertical management
10	CPI	12176-701	Cable management patch panel 19" wide cable support bar
11	CPI	11275-712	Ladder rack, black, 12" wide, 10' long
12	CPI	11275-718	Ladder rack , black 18" wide, 10' long
13	CPI	11275-724	Ladder rack, black, 24" wide, 10' long
14	CPI	11791-718	Rack, wall mount Swing Gate 38.5"H X 19"W X 18"D, black
15	CPI	10595-712	3" Runway mounting plate, rack to runway with hardware, black 9" to 12"
16	CPI	10595-718	3" Runway mounting plate, rack to runway with hardware, black 15" to 18"
17	CPI	12408-724	3" Runway mounting plate, rack to runway with hardware, black 20" to 24"
18	CPI	11308-701	J-Bolt Kit 2.25" length
19	CPI	11308-705	J-Blot Kit 3.25" length
20	CPI	11746-712	Triangular Wall Support Bracket for 12" ladder rack
21	CPI	11746-718	Triangular Wall Support Bracket for 18" ladder rack
22	CPI	11746-724	Triangular Wall Support Bracket for 24" ladder rack
23	CPI	10506-702	Cable Runway Elevation Kit 2" to 3" high
24	CPI	10506-706	Cable Runway Elevation Kit 4" to 6" high
25	CPI	12100-706	Cable Runway Radius Drop 6" Wide
26	CPI	12100-709	Cable Runway Radius Drop 9" Wide
27	CPI	12100-712	Cable Runway Radius Drop 12" Wide
28	CPI	12100-718	Cable Runway Radius Drop 18" Wide
29	CPI	12578-527	66 Block Mounting system 35" W x 7' H holds 2700 pair
30	CPI	11421-712	Wall Angle Support Kit, Cable Runway Black for 12" runway
31	CPI	11421-718	Wall Angle Support Kit, Cable Runway Black for 18" runway
32	CPI	11421-724	Wall Angle Support Kit, Cable Runway Black for 24" runway
33	CPI	10596-706	Cable Retaining Post 6"
34	CPI	11268-001	L Bracket Cable Runway
35	CPI	31470-712	Cable Runway Standoff Support Kit
36	Belden	1701A	Belden CAT 5E Data Twist DT350 OD: .195
37	Belden	7852a	Belden CAT 6 Data Twist 600e OD: .255
38	Belden	10GX33D151000	Belden CAT 6A OD: .295
39	Corning	CCH-04U	72/288-F Rack-MT Enclosure, 19", 4U, empty
40	Corning	PCH-04U	144/288-F Rack-Mount Enclosure, 19", 4U, Empty

41	Corning	CJP_01U	1RU Fiber Jumper Management Panel
42	Corning	CJP-03U	3U Fiber Jumper Management Panel
43	Corning	95-000-41	Multimode SC connector, 62.5/125 CER pre-polished stub
44	Corning	95-050-99	Multimode LC connector, 50 Micron fiber OM2
45	Corning	95-050-99-X	Multimode LC connector, 50 Micron fiber OM3
46	Corning	95-200-41	Single mode SC connector, 0.9/3.0MM CER pre-polished stub
47	Corning	95-200-99	Single mode LC connector
48	Panduit	CPP24WBLY	24 port patch panel, unloaded, snap in 4-port modules, black, no labels
49	Panduit	CPP48WBLY	48 port patch panel, unloaded, snap in 4-port modules, black, no labels
50	Panduit	CJ688TGBU	1 port, modular UTP jack, TX6, cat 6 minicom, blue
51	Panduit	CJ5E88TEI	1 port modular UTP jack, cat 5e Giga-TX mini jack,, Electric Ivory
52	Panduit	CJ5E88TOR	1 port modular UTP jack, cat 5e Giga-TX mini jack, orange
53	Panduit	CJ5E88TGGR	1 port modular UTP jack, cat 5e Giga-TX mini jack, green
54	Panduit	CJ5E88TGVL	1 port modular UTP jack, cat 5e Giga-TX mini jack, violet
55.	Panduit	CJ5E88TGYL	1 port modular UTP jack, cat 5e Giga-TX mini jack, yellow
56	Panduit	CFPSE4EI	4 port, executive flush mount single gang sloped, electric ivory face plate
57	Panduit	CPFSL6EIIY	6 port, executive flush mount single gang sloped, electric ivory face plate
58	Panduit	CFFP4EI	Mini-Com snap-on modular furniture faceplate
59	Panduit	CMBEI-X	1- port blank insert mini-com electric ivory 10 piece kit
60	Panduit	CBEEIY	Mini-Com classic and executive faceplate frames
61	Panduit	CHFMEI-X	2 module space, 1/3 size, flat insert accepts two Mini-Com modules
62	Panduit	PLF1MA-C	Cable tie, 5.1", .75" bundle dia natural 100/pk marker flag, 0-100 pair
63	Panduit	PL3M2S-L	Cable tie, 5.1", .75" bundle dia natural 100/pk marker flag, 100 – 600 pair
64	Panduit	MP250	Cable tie, 5.1", .75" bundle dia natural 100/pk marker flag, 600 pair and up
65	Panduit	HLS-75R0	Velcro strip tie 900" 50lb .75"w, black 75ft/roll ROHS
66	Panduit	KWP5Y	Stainless steel wall plate with Cat 5e module
67	Panduit	GB4B0624TPI-1	TMGB 1/4" x 4" x 20" BICSI/J-STD-607-A Grounding Busbar
68	Panduit	GB4B0612TPI-1	TGB 1/4" x 4" x 12" BICSI/J-STD-607-A Grounding Busbar
69	Panduit	RGRB19U	19" rack mounted grounding busbar kit
70	Panduit	GACB-1	L-bracket auxiliary support bracket
71	Panduit	GACBJ618U	#6 AWG bonding wire to bond two pieces of ladder rack
72	Panduit	ACG 24K	Armored Fiber grounding Kit for cables less than .84 inches in diameter
73	Panduit	ACG 24K-500	Armored Fiber grounding Kit for cables 084 to 1.03 inches in diameter
74	Panduit	CJ688TGBU	Mini-Com Cat6 TX6 Plus Keystone Jack Blue
75	Panduit	CJ6X88TGBL	Mini-Com Cat6a UTP Keystone Jack Black
76	Panduit	CJ688TGYL	1 Port – Modular UTP jack – TX6 Cat6 Mini-Com Yellow

77	Panduit	CJ688TGOR	1 Port – Modular UTP jack – TX6 Cat6 Mini-Com Orange
78	Panduit	CJ688TGGR	1 Port – Modular UTP jack – TX6 Cat6 Mini-Com Green
79	Panduit	CJ688TGVL	1 Port – Modular UTP jack – TX6 Cat6 Mini-Com Violet
80	B-Line	BCH6	4” J-Hook
81	B-Line	BCHSB64-2D	18” Long hanger with 4 – 4” J-Hooks
82	B-Line	SB7200404B	Wall mounted x-connect frame for 66 blocks 4 x 4 16 blocks
83	B-Line	SB7200405B	Wall Mounted x-connect frame for 66 blocks 4 x5 20 blocks
84	B-Line	SB7200410C	Wall Mounted x-connect frame for 66 blocks 4 x 10 40 blocks
85	Caddy	CAT21BC	1” J-Hook with beam clamp attached
86	Siemen	S66M150	66 block
87	Siemen	SB89B or D	Mounting Bracket for 66 block
88	Siemen	MH-50-49	100 Pair Metal housing
89	Siemen	S66B3-50	66 block for 100 pair metal housing
90	Siemen	CC-2024-tb-dc	4 X 2 Wall Mounted Cross Connect Assembly
91	Siemen	CC-2025-tb-dc	5 X 2 Wall Mounted Cross Connect Assembly
92	Valcom	V-9022	Lay-in Ceiling speaker 2 x 2 with builtin backbox one-way amplified
93	Valcom	V-1020C	8” ceiling speaker one-way amplified
94	Valcom	V-9914-5	Bridge for 8” ceiling speaker
95	Valcom	V-9915	Backbox for 8” ceiling speaker requires V-9914
96	Valcom	V-9916	Bridge/Backbox combo for 8” ceiling speakers
97	Valcom	V-2000A	1 Zone page control with power
98	Valcom	V-2001A	1 Zone page control with power
99	Valcom	V-2003A	3 Zone page control with power
100	Valcom	V-2006A	6 Zone page control with power
101	Telect	027-2000-4015	4” CableLinks Adapter (Off-Ramp) - Yellow
102	Telect	027-2000-6499	6” Coupling Kit - Yellow
103	Telect	027-2000-4065	4” Express Off-Ramp - Yellow
104	Telect	027-2000-4403	4” Slotted Trough - Yellow
105	Telect	027-2000-6401	6” Trough - Yellow
106	Telect	027-2000-6424	6” L-Shaped Transition - Yellow
107	Telect	027-1000-4051	Treaded Rod Bracket
108	Telect	027-1000-4002	Standard 5/8” Allthread Kit
109	Telect	027-2000-6408	6” End Cap - Yellow
110	Telect	027-2000-6409	6” Trough End Attachment
111	Telect	027-2000-4265	2” Express Off-Ramp - Yellow
112	Telect	027-1000-4207	2” CableLinks Adapter
113	Telect	027-2000-4203	2” Slotted Duct
114	Telect	027-2000-4090	4” CableLinks Adapter - Yellow
115	Telect	027-2000-6475	6” Trumpet Attachment
116	Telect	027-2000-6410	6” T-Shaped Transition - Yellow
117	Panduit	GB4B0624TPI-1	4”W x ¼”H x 20”L Telecomm Grounding Bussbar
118	Panduit	GB4B0612TPI-1	4”W x ¼”H x 12”L Telecomm Grounding Bussbar
119	Panduit	RGRB19U	19” Grounding Bussbar
120	Panduit	RGCBNJ660P22	Ground Clamp
121	Panduit	HTCT2-2-1	Copper H-Tap
122	Panduit	CLRCVR2-1	H-Tap Cover
123	Panduit	PST - FO	Self-Laminating Fiber Optic Cable Marker Tags
124	Panduit	CP48WSBLY	Mini-com 48 port all metal modular Patch panel with support bar
125	Suttle	SE-630AD4	Analog wall Jack
126	Corning	CCH-CP12-E4	Corning Adapter Panels (OM3)
127	Corning	CCH-CP12-A9	Corning Adapter Panels (SM)

128	Panduit	FiberRunner	FiberRunner Routing Systems - Yellow Tray, Various Sizes
129	Corning	CCH-CS12-A9-P00RE	(SM, LC, 12-fiber adaptor panel)
130	Corning	CCH-CS24-A9-P00RE	(SM, LC, 24-fiber adaptor panel)
131	Corning	CCH-CS12-E4-P00TE	(OM3, LC, 12-fiber adaptor panel)
132	Corning	CCH-CS24-E4-P00TE	(OM3, LC, 24-fiber adaptor panel)
133	Belden	AX103114	24 port patch panel
134	Belden	AX103115	48 port patch panel
135	Belden	AX104193	Cat 6 Blue jack
136	Belden	AX104191	Cat 6 Yellow jack
137	Belden	AX104192	Cat 6 Green jack
138	Belden	AX101319	Cat 6 Almond jack
139	Belden	AX101308	Cat 5E Almond jack
140	Belden	AX102005	Wall phone Plate Stainless
141	Belden	AX106567	Mediaflex face plate sloped with 2 labels/blanks
142	Belden	AX102261	Blank for Mediaflex sloped
143	Belden	AX102428	Mediaflex flush faceplate Almond
144	Belden	AX103926	Furniture adapter 4 port: Almond
145	Belden	AX102901	Furniture adapter 4 port Black
146	Belden	AX102900	Furniture adapter 4 port Elec White
147	Belden	AX104194	Cat 6 Purple Jack
148	Belden	AX102283	Cat 6A Black Jack
149	WBT	Shaped Cable Tray	Cable Tray (WB Tray)

